

RECLAMATION

Managing Water in the West

Facilities Instructions, Standards, and Techniques
Volume 1-2

Conduct of Power Operations



U.S. Department of the Interior
Bureau of Reclamation
Denver, Colorado

June 2012

REPORT DOCUMENTATION PAGE

Form Approved
OMB No. 0704-0188

Public reporting burden for this collection of information is estimated to average 1 hour per response, including the time for reviewing instructions, searching existing data sources, gathering and maintaining the data needed, and completing and reviewing this collection of information. Send comments regarding this burden estimate or any other aspect of this collection of information, including suggestions for reducing this burden to Department of Defense, Washington Headquarters Services, Directorate for Information Operations and Reports (0704-0188), 1215 Jefferson Davis Highway, Suite 1204, Arlington, VA 22202-4302. Respondents should be aware that notwithstanding any other provision of law, no person must be subject to any penalty for failing to comply with a collection of information if it does not display a currently valid OMB control number. **PLEASE DO NOT RETURN YOUR FORM TO THE ABOVE ADDRESS.**

1. REPORT DATE (DD-MM-YYYY)T June 2012		2. REPORT TYPE Final		3. DATES COVERED (From - To)T Implement by January 1, 2013.	
4. TITLE AND SUBTITLE FIST 1-2 Conduct of Power Operations				5a. CONTRACT NUMBER	
				5b. GRANT NUMBER	
				5c. PROGRAM ELEMENT NUMBER	
6. AUTHOR(S) Dave Arend, Larry Ball, Jim Hicks, Mike McKay, Talmadge Oxford, Kevin Shomaker, Rob Skordas, Roger Williams				5d. PROJECT NUMBER	
				5e. TASK NUMBER	
				5f. WORK UNIT NUMBER	
7. PERFORMING ORGANIZATION NAME(S) AND ADDRESS(ES) Bureau of Reclamation Denver Federal Center P.O. Box 25007 Denver CO 80225-0007				8. PERFORMING ORGANIZATION REPORT NUMBER FIST	
9. SPONSORING / MONITORING AGENCY NAME(S) AND ADDRESS(ES) Power Resources Office, Technical Resources Office Bureau of Reclamation Mail Code 86-61600 PO Box 25007 Denver CO 80225-0007				10. SPONSOR/MONITOR'S ACRONYM(S) PRO	
				11. SPONSOR/MONITOR'S REPORT NUMBER(S)	
12. DISTRIBUTION / AVAILABILITY STATEMENT Available from the National Technical Information Service, Operations Division, 5285 Port Royal Road, Springfield, Virginia 22161					
13. SUPPLEMENTARY NOTES					
14. ABSTRACT The Bureau of Reclamation (Reclamation) operates and maintains 53 hydroelectric powerplants and many switchyards, pumping plants, and associated facilities which are important to electric power and water delivery systems. These facilities house complex electrical and mechanical equipment; and protective relays and associated circuits play an essential role in protecting this equipment as well as the electric power system. FIST Volume 1-2 lists the policies and best practices associated with managing the operations of these Bureau of Reclamation power facilities.					
15. SUBJECT TERMS					
16. SECURITY CLASSIFICATION OF:			17. LIMITATION OF ABSTRACT U	18. NUMBER OF PAGES	19a. NAME OF RESPONSIBLE PERSON Power Resources Office
a. REPORT U	b. ABSTRACT U	c. THIS PAGE U			19b. TELEPHONE NUMBER (include area code) 303-445-2922

**Facilities, Instructions, Standards, and Techniques
Volume 1-2**

Conduct of Power Operations

Power Resources Office



**U.S. Department of the Interior
Bureau of Reclamation
Denver, Colorado**

June 2012

Disclaimer

This written material consists of general information for internal use only by Bureau of Reclamation operations and maintenance staff. Information contained in this document regarding commercial products or firms may not be used for advertising or promotional purposes and is not to be construed as an endorsement or deprecation of any product or firm by the Bureau of Reclamation.

Acronyms and Abbreviations

ac	alternating current
ACE	Area Control Error
AF	acre-feet
AGC	automatic generation control
AUTO	automatic
AVR	automatic voltage regulator
CIP	Critical Infrastructure Protection
COO	Continuity of Operations
CFS	cubic feet per second
D&S	Directive and Standard
Dc	direct current
DCS	Distributed Control System
DOC	Designers Operating Criteria
EAP	Emergency Action Plan
EOP	Emergency Operation Procedures
EPP	Emergency Preparedness Plan
FERC	Federal Energy Regulatory Commission
FIST	Facilities Instructions, Standards, and Techniques
GADS	Generating Availability Data System
GDACS	Generic Data Acquisition and Control System
HECP	Hazardous Energy Control Program
HVAC	heating, ventilation, and air conditioning
IAW	in accordance with
ICS	Industrial Central Systems
JHA	Job Hazard Analysis
kVA	kilovoltampere
kW	kilowatt
kWhr	kilowatthour
LE	Late Entry
NERC	North American Reliability Corporation
O&M	operation and maintenance
OSHA	Occupational Safety and Health Administration
PMA	Power Marketing Administrations
PMG	Permanent Magnet Generator
POMTS	Power Operations and Maintenance Tracking System
PRO	Power Resources Office
PSS	power system stabilizer
Reclamation	Bureau of Reclamation
rpm	revolutions per minute
RSHS	Reclamation Health and Safety Standards
SCADA	Supervisory Control and Data Acquisition
SCBA	Self-Contained Breathing Apparatus

Acronyms and Abbreviations (continued)

SF₆	Sulfur Hexafluoride
SOP	Standing Operating Procedures
SPCC	Spill Prevention, Control, and Countermeasures Plan
SSG	Speed Signal Generator
SSP	Site Security Plan
UPS	Uninterruptible Power Supply
WECC	Western Electricity Coordinating Council

Table of Contents

	<i>Page</i>
Acronyms and Abbreviations	iii
1. Introduction.....	1
1.1 Purpose.....	1
1.2 Scope.....	1
1.3 Regulatory Requirements.....	1
1.4 Reclamation Standard Practices.....	2
1.5 Effect of Section Headings	2
2. Responsibility and Authority	2
2.1 Operations Manager.....	2
2.2 Operations Staff	3
2.3 Maintenance Manager.....	4
2.4 Maintenance Staff	4
3. Operating Procedures and Criteria.....	5
3.1 Standing Operating Procedures.....	5
3.2 Review and Revision	5
3.3 Operating Limits	6
3.4 Emergency Action Plan	7
3.5 Emergency Preparedness Plan	7
3.6 Site Security Plan.....	7
3.7 Spill Prevention Control and Countermeasures.....	7
3.8 Continuity of Operations Plan	7
3.9 Designer’s Operating Criteria (DOC).....	8
4. Control Center and Control Room Operations	8
4.1 General.....	8
4.2 Guidelines	8
4.3 Operations.....	9
4.4 Communications	9
4.5 Outage Scheduling and Coordination	10
4.6 Unexpected Event Program (FIST 6-3)	10
4.7 Hazardous Energy Control Program (FIST 1-1).....	10
4.8 Station Log.....	10
5. Powerplant Operations.....	16
5.1 General	16
5.2 Guidelines	16
6. Industrial Control Systems.....	17
7. Operations Training Program	17

Appendices

Appendix A – References	19
Appendix B – Definitions	21
Appendix C – Operations Staff Training Outline	25
Appendix D – Equipment Labeling	27
Appendix E – Reporting	29
Appendix E-1 – Instructions for Completing Form PO&M-59, “Monthly Report of Power Operations – Powerplants”	31
Appendix E-2 – Instructions for Completing Form PO&M-59A, “Monthly Report of Power Operations – Pumping Plants”	39
Appendix E-3 – Instructions for Completing Form PO&M-59B, “Monthly Report of Power Operations – Pumping-Generating Plants”	47
Appendix E-4 – Instructions for Completing Form PO&M-59C, “Monthly Report of Power Operations – Continuation Sheet”	57
Appendix E-5 – Instructions for Completing Form PO&M-62, “Monthly Report of Transmission System Outages”	59
Appendix E-6 – Instructions for Completing Automatic Voltage Regulator and Power System Stabilizer Reports	73
Appendix F – Facility Abnormal Operations.....	77

1. Introduction

The Bureau of Reclamation (Reclamation) operates and maintains 53 hydroelectric powerplants and many switchyards, pumping plants, and associated facilities in the 17 Western United States. These facilities are critical to the electric power and water delivery systems relied on by many. These facilities house complex electrical and mechanical equipment that must be properly operated to ensure reliability. Power Operation Managers must ensure the safe and sound operation of all structures and equipment associated with the fulfillment of this responsibility.

1.1 Purpose

More advanced designs of generators, transformers, and breakers, and associated automatic, semiautomatic, and remote supervisory control equipment are being installed in Reclamation stations; therefore, operating problems are becoming more complex. Uninterrupted service is a necessity, as even a brief outage of electrical service may result in considerable loss to some power consumers as well as loss of revenue and prestige to Reclamation. Only skilled and well-trained personnel can perform the tasks necessary for efficient, economical, and safe operation of facilities.

1.2 Scope

Effective management of facility operations achieves a high level of safety and performance. Reclamation policies and procedures recognize that protecting the environment, ensuring safety, and efficient operations are compatible goals. Such policies and procedures reflect the standards of excellence used in managing Reclamation facilities. These policies establish standards that ensure Reclamation facilities are operated in the best interest of the public. Management, through policies, will establish a method to ensure proper operation of Reclamation facilities. This manual discusses the policies, resources, and assessment needed to establish a method to ensure the safe and reliable operation of Reclamation power facilities.

1.3 Regulatory Requirements

The Energy Policy Act of 2005 requires that Reclamation comply with reliability standards developed, monitored, and enforced by the North American Electric Reliability Corporation (NERC) and the Western Electricity Coordinating Council (WECC). Reclamation's policy to comply with the Standards is documented in the Reclamation Manual, Policy FAC-P13 – *North American Electric Reliability Corporation Electric Reliability Standard Compliance*; detailed responsibilities for compliance with the Standards are described in the Reclamation Manual,

Directives and Standards (D&S) FAC 13-01 – *North American Electric Reliability Corporation (NERC) Electric Reliability Standard Compliance.*

1.4 Reclamation Standard Practices

Refer to the Reclamation Manual D&S FAC 04-14 for more details concerning Reclamation Standard Practices.

1.5 Effect of Section Headings

Section headings or titles appearing in this document are inserted for convenience only and must not be construed as interpretations of text or a standard practice.

2. Responsibility and Authority

To ensure all structures and equipment used in generation and release of water are operated by qualified personnel in a safe and efficient manner, in the best interest of the public, Reclamation facilities must have an established and effective Operations Management Program. Responsibilities associated with this program include the following:

2.1 Operations Manager

- (1) Maintains awareness of current standards and regulatory requirements and ensures powerplants are operated to meet those standards and requirements.
- (2) Responsible for the review and revision of all documents required for the operation of powerplants.
- (3) Coordinates and communicates with the Maintenance Manager for the safe, efficient, and reliable operation of powerplants.
- (4) Sets priorities and expectations for Operations staff.
- (5) Maintains Operations staffing and expertise (including on-the-job training) at a level that ensures the safe and reliable operation of the facility.
- (6) Provides Operations personnel proper training to perform assigned tasks.
- (7) Provides staff with the necessary tools and resources to perform assigned tasks.
- (8) Uses approved Reclamation, Regional, or Area Office business practices to support development and revision of the following:

- (a) Emergency Action Plan
 - (b) Emergency Preparedness Plan
 - (c) Continuity of Operations Plan
 - (d) Spill Prevention Control and Countermeasure Plan (SPCC)
 - (e) Standing Operating Procedures
 - (f) Operating Limits
 - (g) Emergency Operating Procedures (EOP)
 - (h) Communications Directory
 - (i) Hazardous Energy Control Program
 - (j) Facilities Instructions, Standards, and Techniques (FIST) Manuals
 - (k) Power Reliability Compliance Bulletins
 - (l) Power Equipment Bulletins
- (9) Monitors facility operating performance.
 - (10) Conducts an annual evaluation of the Operator Training Program.
 - (11) Responsible for ensuring that all equipment (or systems) is properly labeled.

2.2 Operations Staff

- (1) Maintain necessary knowledge and skills to perform the duties of their positions.
- (2) Responsible for operating powerplants in compliance with the standards related to operations.
- (3) Ensure Maintenance staff is aware of significant operational events such as outages, special conditions, etc.
- (4) Complete assigned training.
- (5) Report and document powerplant deficiencies.
- (6) Monitor operational data to establish baseline and abnormal plant performance trends.

- (7) Use all approved Reclamation, Regional, Area Office, and Facility procedures including, but not limited to the following:
 - (a) Emergency Action Plan (EAP)
 - (b) Emergency Preparedness Plan (EPP)
 - (c) Continuity of Operations Plan (COO)
 - (d) Spill Prevention Control and Countermeasure Plan (SPCC)
 - (e) Standing Operating Procedures (SOP)
 - (f) Operating Limits
 - (g) Emergency Operating Procedures (EOP)
 - (h) Communications Directory
 - (i) Hazardous Energy Control Program (HECP)
 - (j) FIST Manuals
 - (k) Power Reliability Compliance Bulletins
 - (l) Power Equipment Bulletins

2.3 Maintenance Manager

- (1) Coordinates and communicates with the Operations Manager
- (2) Responsible for all plant and facility maintenance.

2.4 Maintenance Staff

Ensure Operations staff is aware of all maintenance being performed in the powerplant.

3. Operating Procedures and Criteria

3.1 Standing Operating Procedures

- (1) Purpose
 - (a) SOPs provide facility specific information about equipment (or systems) and direction for operating equipment (or systems) during normal and abnormal conditions. Accurate operating procedures are a critical resource influencing an operator's action during normal and abnormal equipment (or systems) operation. Operating procedures should be sufficiently detailed so that the required actions can be undertaken without direct supervision. Operating limits for all equipment (or systems) must be included in the applicable chapters.
 - (b) Emergency operating procedures provide specific direction for operating equipment (or systems) during facility emergencies.
 - (c) Abnormal events are not emergencies; however, the consequences of not dealing with these events in a systematic manner could further complicate the event and may lead to personnel injury, damage to plant equipment, and loss of generation.
 - (d) Responsible operations/maintenance staff should develop alarm response procedures that identify all inputs that initiate annunciator or trouble alarms and the respective response actions.
 - (e) Control Centers must have current copies of the SOPs, including emergency operating procedures, for all facilities they operate.

3.2 Review and Revision

- (1) **[The SOP will be kept current by responsible staff that will review and revise the document at least annually. Responsible staff are those key personnel at the facility, Area Office, and Regional Office qualified to ensure that the SOPs are adequate. Revised procedures should be verified by a second qualified person.]**
 - (a) Procedures are reviewed to ensure that operating procedures are current and updated to address current and newly installed equipment.

- (b) Procedures are reviewed to ensure that all aspects of safety and environmental compliance have been fully addressed before issuance.
- (c) **[The Operations Manager and Facility Manager will review the procedures for accuracy prior to submission to the Regional Director, or assigned designee before approval and distribution.]**
- (d) **[All procedure changes must be reviewed by Operations staff.]**
- (e) Applicable procedures should be reviewed after abnormal events to ensure their adequacy and revised as necessary.

NOTE: To provide uniformity, SOPs should conform to the Standing Operating Procedure Guide for Dams, Reservoirs, and Power Facilities Manual.

3.3 Operating Limits

Knowing and understanding the operating limits of major powerplant equipment is key to successful and reliable operation of the powerplant. Operating limits consist of generator capability curves, operating memos, special conditions, design parameters, maintenance history, etc. **[All powerplants must have clearly established current operating limits readily accessible for reference .]** A capability curve is defined as a curve that shows boundaries of the area on the kilowatt-kilovar diagram within which a machine may operate continuously. Capability curves are furnished for each installation showing the expected range of operation and including the range of permissible operating voltages. Machines should not be operated outside approved operating boundaries..

Reclamation's generators provide our Power Marketing Administrations (and associated Transmission Operators) the reactive and voltage control necessary to ensure voltage levels, reactive flows, and reactive resources. These services are provided while operating the generation equipment within their applicable Facility Ratings to protect the equipment. Capability curves define this rating and are, therefore, critical Operator requirements for the safe operation of the facility.

In extreme emergencies where a lack of generation might cause power system instability or breakup, it may be necessary to overload machines briefly in excess of the normal loading limit and/or maximum temperature permitted by insulation class. Old machines that have been uprated, new machines (post-1982), and machines under warranty (new, recently rewound or uprated, etc.) should not be operated above rated capacity as uprated, and new machines may not have overload capabilities. When overloading is done, a sacrifice in insulation life must be expected, and the risk of mechanical damage to the machine must be considered. Capability curves also provide insight into which operating

parameters are being challenged, thus identifying data points where increased monitoring is required.

The operating limits of other equipment such as cables, buses, reactors, circuit breakers, disconnecting switches, current transformers, and power transformers also should be known. Any one of these may constitute the practical limit in load carrying ability of the unit. On the machine itself, the limits of auxiliary equipment such as exciters or rheostats should be known. The exciter should have sufficient margin while carrying the overload to take care of small fluctuations in load and voltage that may occur with minor system disturbances. In some cases, it may be possible to ease the burden on the exciters of the machine being overloaded by transferring reactive kilovoltampere (kVA) to other units of the same system.

3.4 Emergency Action Plan

The EAP outlines emergency action procedures for each facility. It includes detection of an event, decisionmaking, notification, response levels, expected actions, and emergency termination. It covers events such as earthquakes, fires, floods, dam failures, etc. (See Reclamation Manual D&S FAC 01-01.)

3.5 Emergency Preparedness Plan

The EPP includes detailed and specific response, communication, and evacuation procedures for each office, department, and employee during emergencies such as fires, bomb threats, terrorist activities, hazardous materials spills, and other manmade (localized) emergencies. This is an obsolete document that is being replaced by the EAP, Site Security Plan (SSP), and SPCC documents.

3.6 Site Security Plan

The SSP will document security systems, procedures, and responsibilities for both normal operations and responses to threat conditions or other emergency security incidents. The SSP will be integrated into, or used closely in conjunction with, SOPs, EAPs, Continuity of Operation Plans, and other emergency occupancy and evacuation plans. (See Reclamation Manual D&S SLE 03-02.)

3.7 Spill Prevention Control and Countermeasures

The SPCC includes the procedures to prevent and control oil spills from the facility into or upon the waters below or above the dam. (See FIST 6-1.)

3.8 Continuity of Operations Plan

Ensures that essential Reclamation operations and activities are continued in the event of an emergency or threat of an emergency at any Reclamation facility.

This requires identifying functions that would have to be performed during and after such an emergency, developing plans to performing these functions, and developing the capability to execute those plans. (See Reclamation Manual D&S FAC 05-01.)

3.9 Designer's Operating Criteria (DOC)

Intended to provide the field personnel engaged in operation and maintenance with the designer's views on the proper use of the original project features. The DOC is a historical document that is not kept current with changes in equipment or facility operating practice. In many cases, DOCs were not created for the facility. (See Reclamation Manual D&S FAC 03-02.)

4. Control Center and Control Room Operations

4.1 General

The Control Center and Control Room is the coordination point for all operations of equipment (or systems) under the jurisdiction of the Operator including all coordination with the Transmission Operator, Balancing Authority, and System Operators.

4.2 Guidelines

(1) Controls

- (a)** The Regional Director or assigned designee must establish and document a security plan (site or physical) to control physical access to the Control Center and Control Room. The plan must conform to current Critical Infrastructure Protection (CIP) standards.
- (b)** The Operations Manager is responsible for assuring professional behavior in the Control Center or Control Room.
- (c)** The Operations Staff on duty has the authority to restrict access to the Control Center or Control Room and to remove personnel as deemed necessary.

4.3 Operations

(1) Duties

- (a) Operations Staff operate facility equipment, monitor equipment operating parameters, respond to malfunctions and alarms according to established procedures, and perform administrative tasks.
- (b) Operations Staff must:
 - (i) Log any changes in operating conditions and report abnormal conditions to appropriate personnel for corrective actions.
 - (ii) Be familiar with the functions and operating limits of facility equipment and systems.
 - (iii) Be aware of all work that is being performed on equipment (or systems).
 - (iv) Verify equipment (or systems) can be removed from service without adversely affecting other operating systems or entities.
 - (v) Inform the Transmission Operator and other appropriate personnel immediately of any emergency or abnormal condition that affects system operation.
 - (vi) Manage the Operational Configuration of the facility per FIST Volume 1-1.
 - (vii) Comply with all applicable reliability compliance regulations including making proper notifications required by those regulations.

4.4 Communications

- (1) Communications must be concise, reliable, and accurate.
- (2) Operations Staff will use audio and visual warning devices to alert personnel to abnormal or emergency conditions within the facility. All persons entering the facility must be provided information concerning these warning devices and expected responses.
- (3) Each facility must have established plans that identify response procedures, alternate communication systems or methods, and contact information to address loss or disruptions of the normal communication system.

- (4) **[Three-part communications must be used during switching, emergency situations, critical operations, and all communications with the Transmission Operator.]**
- (5) **[Communications with Transmission Operators are critical and require documentation, which may be in the form of either voice file, electronic, or written log.]**

4.5 Outage Scheduling and Coordination

The Operations Manager must develop policies and procedures to schedule outages including communication and coordination with Transmission Operators, Maintenance Managers, etc.

- (1) Unit outage schedules must be current.
- (2) Unit availability. (See Reclamation Manual D&S FAC 04-12.)

4.6 Unexpected Event Program (FIST 6-3)

This program is a structured approach to evaluate and document unexpected events. This is accomplished by a defined process of event assessment that is tailored in scope and depth to the severity of the event. This Unexpected Event Reporting Program is intended to be a learning tool for the betterment of Reclamation's operations and maintenance programs through self-examination and information sharing. Refer to FIST 6-3 for program requirements.

4.7 Hazardous Energy Control Program (FIST 1-1)

This document establishes consistent procedures for the control of hazardous energy and to maintain operational control of a facility's configuration. This includes activities affecting operation, maintenance, and construction of those Federal facilities for which Reclamation is responsible. Refer to FIST 1-1 for program requirements.

4.8 Station Log

- (1) Requirements
 - (a) A station log will be maintained at each facility in the Control Center and Control Room. The station log contains a chronological record of all operating activities and events, which provides a reference for future use. Operations personnel use this information to evaluate present and past plant status. The station log may be paper, electronic, or a combination of both and include (where applicable) the

Operating Log Book, Sequence of Events Recorder data, MW and Elevation charts, Security logs, etc. Completed station logs will be kept as a permanent record in a secure location.

(2) Activities

- (a) The station log will document the following activities, as a minimum:
 - (i) Operations Staff on duty.
 - (ii) All operations of waterway equipment including gates, valves, and changes to spillway gate positions.
 - (iii) Communications involving plant operations, switching, Hot Line Orders, Clearances, Special Conditions, alarms, and relay operations. **[All Communications with Transmission Operators shall be logged].**
 - (iv) Water elevations and releases and operational changes affecting water elevations and releases (unless reported on water supply forms or approved daily record).
 - (v) Status of auxiliary equipment.
 - (vi) Testing of equipment or gate controls.
 - (vii) Acts of vandalism or other security incidents.
 - (viii) Requests and concurrence to change from normal operation during an emergency or unusual conditions.
 - (ix) Communications network checks and emergency exercises conducted.
 - (x) The disabling and re-enabling of facility alarms.
 - (xi) Unit start and stop times.
 - (xii) Any equipment failures or malfunctions.
 - (xiii) [Automatic voltage regulator (AVR), AVR Mode, and power system stabilizer (PSS) change in status and documentation that the Balancing Authority was notified of any change in status within 30 minutes].**
 - (xiv) Line outages.
 - (xv) Breaker opening and closing.

- (xvi) Callouts.
- (xvii) Any change in unit status (condensing, available, unavailable, etc.).
- (xix) Status of all major equipment; active clearances, hot line orders, special conditions; and elevations at 0000 hours (or when staffed). Printed reports can supplement Log Book entries including software programs that are able to generate midnight (0000 hours) reports to capture this information. The reports become part of the permanent log.
- (xix) Listing of personnel (visitors) arrival and departure (unstaffed stations).

(3) Operating Log Book

- (a)** The Operating Log Book may be a bound paper book or an electronic document. Only authorized personnel may make entries in the log. Under no circumstances will pages be removed from permanent logs, regardless of whether they are manual or computer generated. The operating log is a legal record of facts about project operations. Personal opinions and comments are not to be entered in the operating log.

NOTE: Where an electronic log is used, the paper hard copy must be maintained.

(4) Entries

- (a)** The following will apply to all entries in the Operating Log Book.
 - (i)** Operating Log Book entries must be made by the identified authorized individual(s).
 - (ii)** All entries must be typed, legibly handwritten, or stamped in ink. Such entries must be made as soon as practicable after the action has been accomplished.
 - (A)** Red must be used only for issuing clearances (hot line orders).
 - (B)** Green must be used only for releasing clearances (hot line orders).
 - (C)** Black must be used for all other general entries.

- (iii) Errors in log entries must be voided by drawing a single line through the error, dated, and initialed by the person making the correction.
- (iv) Electronic logs must be password protected.
- (v) The Operating Log entries must be based on the 24-hour clock.
- (vi) A new page should be started for each new date using the following format: mm/dd/yyyy. Facilities with limited log entries (such as unattended facilities) may have multiple days recorded on a single page by logging the date and time for each entry.
- (vii) If a log entry is made out of chronological order, the phrase "Late Entry" or "LE" must be used.
- (viii) Acronyms and abbreviations, as established by each facility, are acceptable for log entries.
- (ix) [When transmission lines are referenced in the logbook they will use the Transmission Operator's standard terminology].**

(5) Review

- (a) **[The Operations Manager must review and initial the Operating Log Book. Review of the Operating Log Book will occur each normally scheduled workday for fully staffed facilities, at least weekly for facilities with duty operators, and at least monthly for unstaffed facilities. The Operating Log Book will be reviewed to verify that each of the activities and entries listed above were correctly entered, entries not made that should have been, and Late Entry Corrections are made as necessary.] In addition, the Operating Log book entries should be reviewed over a longer period to determine if there are trends that need to be addressed by maintenance or others.**

(6) Shift Turnover

- (a) Shift turnover is a critical part of the facility's or Control Center's operation and provides oncoming Operations staff with an accurate picture of the overall status of the facility.
 - (i) Oncoming Operations staff must review logs, turnover checksheet (if used), Supervisory Control and

Acquisition (SCADA) displays, alarm displays, disabled alarms, protective devices, and computer pages; and they must receive a verbal briefing from the on-duty operator prior to assuming responsibility for the operation of the facility. Where applicable, a visual inspection of control boards, including a test of the annunciator windows, will be completed to verify indication/annunciation lights are operational.

- (ii) At a minimum, the following information should be exchanged during a shift turnover: major equipment status, alarm status, work in progress, hazardous energy control (HEC) procedures, any abnormal plant conditions, water releases, power schedules, and work scheduled.
- (iii) The operation staff then will sign into the log documenting that shift turnover has been completed.

(7) Operator Aids

- (a) Operator aids have an important function in the safe operation of the facility. Operator aids must:
 - (i) Be posted so they do not obscure instruments or controls.
 - (ii) Be located near the area of their expected use.
 - (iii) Supplement approved procedures.
 - (iv) Be documented.
 - (v) The Operations Manager must:
 - (A) Approve all operator aids.
 - (B) Ensure operator aids are current.
 - (C) Review operator aids at least annually to ensure accuracy and necessity.

(8) [Reporting (see appendix E)]

(a) Monthly Report of Power Operations.

The Power Operations and Maintenance Tracking System (POMTS) is Reclamation's electronic system for entering, storing, and retrieving the PO&M-59, -59B, AVR, and PSS information. The POMTS includes fillable fields for

data entry (similar to the PO&M-59 and 59B report forms); performs automatic calculations; provides areas to report the AVR and PSS status; and includes options to run various reports, such as pdf copies of the PO&M-59, -59B, AVR, and PSS reports.

Depending on the individual's authorized access rights, data entry, retrieval, report revisions, etc., can be performed. The POMTS includes user instructions titled "Enter PO&M-59 Power Plant Information," "Enter PO&M-59B Pump-Gen Plant Information," and "Cause Code Description and Numbers." See the POMTS Web site located at <http://intra.usbr.gov/itops/information-services/apps/POMTS/login/login.cfm> for more information.

The PO&M-59, -59B, AVR, and PSS reports normally will be completed using the POMTS system. If the POMTS system is unavailable, a PO&M-59 and -59B report form and AVR/PSS reports will be completed and submitted. The PO&M-59A is the report for pumping plants, which is not currently included in the POMTS system. Until it is incorporated, a PO&M-59A report form must be completed. The PO&M-59C report form is a continuation sheet for the PO&M-59 report form and would only be used if the POMTS system was unavailable and additional lines were needed to complete the PO&M-59 report form.

The PO&M-59, PO&M-59A, PO&M-59B, (PO&M-59C if applicable) AVR, and PSS information must be completed and distributed within the Region, as specified by the Regional Director, and to the Power Resources Office (PRO) no later than the 10th calendar day of the month following the reporting month. When submitting report form(s), use the address identified on the bottom of the respective report form.

(b) Report of Monthly Transmission System Outages.

Report of Transmission System Outages (PO&M-62 report form) will be completed for Region's designated as transmission owners. The PO&M-62 is not currently included in the POMTS system, and until it is incorporated, a PO&M-62 report form must be completed. One report is to be prepared for each operating area, covering all transmission system outages in the area during the reported month. The report must

be distributed within the Region as specified by the Regional Director, with a copy to the PRO (address identified on the bottom of the PO&M-62 report form). The copy for PRO must be received by no later than the 10th calendar day of the month following the reporting month.

- (i) Reading of Revenue Meters. Readings must be made at least monthly of all revenue meters and the records retained for at least 6 years.]**

NOTE: The report must be distributed within the Region as specified by the Regional Director.

5. Powerplant Operations

5.1 General

Effective monitoring of equipment is necessary to detect abnormal conditions or adverse trends. Monitoring allows actions to be taken before the equipment malfunctions. All facility operations must use the SOP.

5.2 Guidelines

- (1) Powerplant Inspections**
 - (a)** Inspections must be of sufficient detail to ensure that the status of equipment is known. Operations staff periodically must conduct a thorough inspection of all areas within their responsibility and report and document all deficiencies per facility requirements.
- (2) Inspection Sheets:**
 - (a)** Are useful for tracking equipment trends.
 - (b)** Provide guidance on the extent to which equipment and areas should be inspected.
 - (c)** Assist Operations staff during shift turnover.
 - (d)** Should include acceptable parameters to assist the Operations staff in identifying abnormal readings.

- (e) Should be periodically reviewed by the Operations Manager to ensure the inspections are being performed.
- (f) Should be reviewed at least annually to ensure relevance and accuracy.

6. Industrial Control Systems

Industrial Control Systems (ICS) include systems called SCADA, GDACS, DCS, etc.. ICS refers to computer-based systems that provide automated equipment control and perform the data collection and processing required to support those control functions. Some Reclamation ICS do not perform any control functions but are solely dedicated to collecting data. Other remote independent systems require operators to supervise actual equipment control. Refer to FIST 3-33, Industrial Control Systems (ICS) Including Supervisory Control and Data Acquisition (SCADA) Systems Operation and Maintenance, for program requirements.

7. Operations Training Program

(1) Requirement

- (a) Each employee must receive training to meet the responsibilities of their position.
 - (i) New or Transferred Employee. The Operations Manager will determine the training requirements, duration of training, and document when an employee is qualified to perform the duties of their position. A checklist should be used to ensure completion of training requirements. All Operations staff is required to familiarize themselves with the facility reference documents, facility systems, policies, and procedures. The Operations Manager selects which facility-specific or other training programs personnel must attend to be qualified to operate or use the facility. The Operations Manager may authorize training exemptions based on an assessment of the individual's experience. Exemptions must be documented.
 - (ii) Continuing. Annual training to ensure Operations staff is proficient in the knowledge and skills needed to perform their duties. Training must be provided sooner if there is a change in job assignments, changes to systems or processes, or a change in procedures.

- (iii) Remedial. Training must be provided when there is a reason to suspect deficiencies or inadequacies in the employee's knowledge or skills.

(2) Methods

- (a) On-the-Job. The primary mode of training for the facility is through on-the-job training. Training must be carefully supervised and controlled to avoid mistakes.
- (b) Instructor-led. Classroom or in the field.
- (c) Computer-based. Online or other.
- (d) Required Reading. Assignments require signatures by the employee to indicate that they have read and understand the document.

- (3) Assessment.** Knowledge and skills should be evaluated by the Operations Manager. The assessment methods must be documented and approved by the Operations Manager.

- (4) Documentation.** All training must be documented in DOI Learn.

- (5) Program Review.** The Operations Manager should review the training program annually and recommend any changes or improvements.

- (6) Operator Training Outline** (see appendix C).

Appendix A – References

- Facilities Instructions, Standards, and Techniques (FIST) 1-1, Hazardous Energy Control Program, Section 19.5.3, March 2002
- FIST 1-2, Operations and Maintenance Improvement Program, May 1989 (errata needed)¹
- FIST 1-3, Reports and Records, December 1989²
- FIST 1-4, Permissible Loading of Generators and Large Motors, March 1991²
- FIST 1-5, Permissible Loading of Oil-Immersed Transformers and Regulators, April 1991²
- FIST 1-6, Limitations in Manual and Automatic Synchronizing, January 1990²
- FIST 1-7, Numbering Systems, January 1990²
- FIST 1-8, Load Division and Circulating Current in Parallel Operated Transformers, January 1990²
- FIST 1-9, Acceptable Generator Power Transients During Switching, January 1990²
- FIST 1-10, Problem with Two-Breaker Switching Schemes, January 1990²
- FIST 1-11, Conduct of Power Operations, December 2002 (errata needed)²
- FIST 1-12, Abnormal Operations Generic Technical Guidelines for Power Stations, March 2003(errata needed)²
- FIST 3-33, Industrial Control Systems, January 2012
- FIST 4-2, Power O&M Codes for ADP, Revised December 1989
- FIST 6-1, Management of Power Facilities, March 2003 (errata needed)
- FIST 6-2, Conduct of Power Maintenance, March 2006 (errata needed)
- FIST 6-3, Unexpected Event Reporting, August 2011
- Reclamation Safety and Health Standards (RSHS)
- FAC 01-01, Emergency Management

¹ This FIST document will be retired upon approval of the new FIST 1-2, Conduct of Power Operations.

FIST Volume 1-2

FAC 02-01, Operating Practices and Procedures for High and Significant Hazard
Dams

FAC 05-01, Continuity of Operations

North American Electric Reliability Corporation (NERC) Standards

Western Electricity Coordinating Council (WECC) Standards

Appendix B – Definitions

Area Control Error (ACE). The instantaneous difference between a Balancing Authority's net actual and scheduled interchange, taking into account the effects of Frequency Bias and correction for meter error.

Automatic Generation Control (AGC). Equipment that automatically adjusts generation in a Balancing Authority Area from a central location to maintain the Balancing Authority's interchange schedule plus Frequency Bias. AGC also may accommodate automatic inadvertent payback and time error correction.

Available. The period during which a unit is in service or ready for service.

Balancing Authority. The responsible entity that integrates resource plans ahead of time, maintains load-interchange-generation balance within a Balancing Authority Area, and supports Interconnection frequency in real time.

Base Load. The minimum amount of electric power delivered or required over a given period at a constant rate.

Blackstart Resource. A generating unit(s) and its associated set of equipment, which has the ability to be started without support from the System or is designed to remain energized without connection to the remainder of the System, with the ability to energize a bus, meeting the Transmission Operator's restoration plan needs for real and reactive power capability, frequency and voltage control, and that has been included in the Transmission Operator's restoration plan.

Control Center. A control center is responsible for scheduling, monitoring, and operating more than one facility. Usually interacts directly with Operations Staff in power facility Control Rooms, as well as the Transmission Operator, Balancing Authority, or Reliability Coordinator.

Control Room. The area in a power plant from which the Operations Staff monitors and operates plant and system equipment.

Federal Energy Regulatory Commission (FERC). An independent agency that regulates the interstate transmission of electricity, natural gas, and oil. FERC also reviews proposals to build liquefied natural gas terminals and interstate natural gas pipelines as well as licensing hydropower projects. The Energy Policy Act of 2005 gave FERC additional responsibilities related to Transmission system reliability.

Forced Outage. Results in or requires removal of a unit from service due to automatic mechanical, electrical, or hydraulic control systems, operator initiated action, a failure to start when called upon, or a failure of any system that requires it be removed from service.

Generating Unit (Unit). Includes all components, penstocks, gates, valves, generators, turbines and auxiliaries that a generator to operate.

Industrial Control Systems (ICS) (Supervisory Control and Data Acquisition [SCADA], GDACS, or DCS). Computer based systems that provide automated equipment control and perform the data collection and processing required in supporting those control functions.

Inspections. Monitoring the operations of plant equipment through local observations and recording appropriate equipment parameters.

Inspection Sheets. Procedures or forms used to record equipment operation and data that provide information necessary for evaluating and trending plant conditions.

Operations Log. Documented records created, maintained, and used by Operations personnel that describe and record operating information and events that aid in evaluating present and past unit or plant status. It may be in either a bound paper book or electronic format.

Operations Manager. The person responsible for setting operational policies at the facility, monitoring operating performance, and assigning and ensuring personnel under their jurisdiction meet the minimum and ongoing requirements of the Operations Training Program. Depending on the local facility practices, this could be the Operations Manager, Operations and Maintenance (O&M) Supervisor, Shift Supervisor, or other.

Operations Staff. Individuals who through initial and proficiency training and on-the-job training demonstrated that they have attained sufficient knowledge to safely and reliably operate the facility and have been authorized by the Operations Manager to perform those duties. This individual may be an Operator, Control Center Operator, Control Room Operator, Electrician Operator, Mechanical Operator, etc.

NERC. The North American Electric Reliability Corporation is the electric reliability organization certified by FERC to develop and enforce reliability standards to be followed by bulk electric systems within North America.

Non-Spinning Reserve. This term means generators capable of providing Operating Reserve, are not connected to the system but are capable of quick starting and producing energy within a specified time. Nonspinning reserve also can-be interruptible load that can be removed from the system in a specified time.

Recorder Charts. A record of plant process instrumentation plotting versus time. The record is automatically charted by the associated instrument. May be electronic in an electronic format.

Required Reading. Materials that operations staff should be knowledgeable of as determined by the Operations Manager and/or Facility Manager.

Scheduled Outage. Results when equipment is deliberately taken out of service at a selected time, usually for construction, maintenance, or repair. A scheduled

outage is planned in advance, has a predetermined duration, and must be coordinated with the Balancing Authority.

Shift Turnover. The process of information and responsibility transfer to the oncoming Operator from the offgoing Operator.

Spinning Reserve. Means that amount of unloaded generation, which is already synchronized and online, can quickly serve additional demand. It consists of Regulating Reserve and Contingency Reserve.

Three-Part Communications. An exchange of information that is clear, concise, and definitive and ensures that the recipient repeats the information back correctly; and the transmitting party acknowledges the response as correct or repeats the original statement until any misunderstandings are resolved.

Unavailable. The period during which a unit is not available for service due to a scheduled or forced outage.

Uniform Line Identifier. A uniform line identifier will consist of a name representing each end of a line segment and the line operating voltage level (i.e., Substation A—Substation B 115 kilovolts (kV)).

WECC. The Western Electricity Coordinating Council is the Regional Entity responsible for enforcing reliability standards within the 17 Western States, British Columbia, Alberta, and parts of Baja Del Norte.

Appendix C – Operations Staff Training Outline

A. Safety

- (1) Reclamation Safety and Health Standards
 - (a) **[Job Hazard Analysis – Section 4]**
 - (b) **[Personal Protective Equipment – Section 8]**
 - (c) **[Personal Fall Protection – Section 16]**
 - (d) **[Confined Spaces – Section 14]**
 - (e) **[First Aid, CPR, and AED – Section 5 (2 years)]**
 - (f) **[Electrical Safety Requirements – Section 12]**
- (2) **[FIST 1-1, Hazardous Energy Control Procedures]**
- (3) **[Switchman Training]**
- (4) **[FIST 5-14, Arc Flash Hazard Program]**

B. Theory

- (1) Electrical Theory
- (2) Mechanical Theory
- (3) Operations Principles

C. Procedural

- (1) **[Emergency Action Plan]**
- (2) Emergency Preparedness Plan
- (3) **[Spill Prevention Control and Countermeasures Plan]**
- (4) **[Continuity of Operations Plan]**
- (5) **[Emergency Operating Procedures]**
- (6) **[FIST 1-2, Conduct of Power Operations]**
- (7) FIST 3-33, Industrial Control Systems
- (8) **[Volume 5 Safety FIST]**
- (9) **[FIST 6-3, Unexpected Event Program]**

- (10) Power Equipment Bulletins
- (11) [Power Reliability Compliance Bulletins]
- (12) [CIP-001 Sabotage Reporting]
- (13) [Automatic Voltage Regulator (AVR)/Power System Stabilizer (PSS) Training]

D. General

- (1) [Dam Tender Training (3 years)]
- (2) [Operating Limits]
- (3) [Plant and System Blackstart Operations]

E. [System Knowledge – Facility SOP Chapters]

F. Offsite Training (suggested)

- (1) Plant Familiarization (plants under direct control of the Operations Staff)
- (2) System Operations
- (3) Western Area Power Administration – EPTC Course
- (4) Western Area Power Administration – Relay Course

Appendix D – Equipment Labeling

A. Scope

A well-established and maintained program for labeling equipment will help to ensure that the facility and support personnel can identify instrumentation, controls, and equipment. In addition, equipment labeling is required by Operational Safety and Health Administration (OSHA) regulations and various national consensus standards.

B. Purpose

A good labeling program that is understood and maintained by Operations and Maintenance personnel enhances the effectiveness of work activities. Such a program also helps to reduce errors by operations and maintenance personnel as errors can result from incorrect identification of equipment and controls.

The labeling program should allow personnel to identify instrumentation, controls, and equipment needing labels. In addition to equipment, doors to rooms should be labeled to help facility and support personnel to identify rooms and, if applicable, the equipment inside.

C. Guidelines

Components Requiring Labeling

At a minimum, the following items should be labeled:

1. Emergency exits, fire alarms, fire protection, and fire extinguishers
2. Rescue and first aid equipment
3. Mimic boards and/or Supervisory Control and Data Acquisition (SCADA) displays
4. Annunciator panels
5. Circuit breakers, disconnects, and power panels
6. Ground switches
7. Valves
8. Piping systems
9. Major plant equipment
10. Control switches
11. Protective devices, including relays
12. Metering

D. Label Information

Label information must be consistent with the information found in facility procedures, drawings, and other documentation. Labels must be permanently attached and have easy-to-read information.

1. The label should use common names of facility systems and equipment, along with a number designator.
2. Valves should be labeled with a number and name describing the purpose consistent with system drawings.
3. Piping systems should be labeled with flow direction and contents.
4. Major plant equipment also should be labeled by equipment number and function.
5. Circuit breakers and panels are labeled so as to designate which circuit they are fed from and what devices they feed.
6. Emergency exits, fire alarms, fire extinguishers, and fire protection equipment are labeled in a standard industrial format.

E. Label Placement

Labels are placed on, or as near as practical to, the controls or equipment being labeled. Labels are oriented so that they are easy to read.

F. Replacing Labels

The Operations Manager (or other designated person) is responsible for ensuring that missing or damaged labels, once identified, are promptly replaced and that newly installed equipment or new modifications to existing equipment are properly labeled.

Appendix E – Reporting

A. Introduction

The complexity of interconnected power systems require increased emphasis on the analysis of system performance to ensure achievement of the best reliability. One of the most important requisites for such analysis is the availability of clear, concise, and accurate reports on power system operations and maintenance (O&M) for review by management at various levels. Specific details regarding preparation, issuance, and distribution of the various Operation and Maintenance Reports are given in the following sections of this appendix.

B. Monthly Project Report of Power O&M Activities

A narrative report of power O&M activities shall be prepared and distributed monthly by the power O&M office(s) on each project that includes operating power facilities.

This report shall briefly describe all important nonroutine events of a power O&M nature that occurred during the month, such as date, time duration of major items of maintenance undertaken or accomplished, new equipment or service installations or connections; changes in system arrangement or interconnections with adjacent utilities; major power interchanges between systems or water movements scheduled or accomplished; new facilities added; important personnel activities; etc.

This report shall be distributed within the Region as specified by the Regional Director by the 20th day of the month following the reporting month.

C. Monthly Report of Power Operations (Operations Report)

The operations report (PO&M-59, PO&M-59A, PO&M-59B, and PO&M-59C, if applicable) for each powerplant, every pumping plant with installed capacity of 15,000 horsepower or greater, and each plant engaged in a combination of power generation and pumping, along with the AVR and PSS information must be completed and distributed within the Region as specified by the Regional Director and to the Power Resources Office (PRO) no later than the 10th calendar day of the month following the reporting month. When submitting report form(s), use the address identified on the bottom of the respective report.

Normal submittal of the PO&M-59 and -59B data is performed by inputting the information into the Power Operations and Maintenance Tracking System (POMTS). Appendix E, figure E-11, is an example of a PO&M-59 POMTS generated report that includes the AVR/PSS information. If the POMTS system is unavailable, a PO&M-59, -59B report form, and AVR, PSS reports will be completed and submitted.

Instructions for completing the respective form and example copies of a blank and completed form are located in appendix E-1 (PO&M-59) , E-2 (PO&M-59A), E-3 (PO&M-59B), and E-4 (PO&M-59C-continuation sheet). Instructions for completing the AVR and PSS reports and a example copy of a completed report are located in appendix E-6.

D. Report of Monthly Transmission System Outages

Report of Transmission System Outages (PO&M-62) will be completed for Region's designated as transmission owners. One report is to be prepared for each operating area, covering all transmission system outages in the area during the reported month. The report must be distributed within the Region as specified by the Regional Director, with a copy to the Chief, Facilities Engineering Branch, Denver Office, Denver, Colorado. The copy for the Denver Office must be forwarded to reach that office by the 20th day of the month following the reported month. Instructions for completing the PO&M-62 form and example copies of a blank and completed form are located in appendix E-5.

Appendix E-1 – Instructions for Completing Form PO&M-59, “Monthly Report of Power Operations – Powerplants”

Figure E-1 is an example of a blank PO&M-59 report form and figure E-3 is an example of a properly completed PO&M-59 report form. One report is to be prepared for each powerplant covering operations each calendar month. The report period starts at midnight (0000) on the first and ends at midnight on the last day of the month (2400). Daylight savings time changes (i.e., 23-hour and 25-hour day) are included in the reports for the respective month in which the time change occurs.

NOTE: In the event the “Unit Service Record” part of the report for an individual powerplant, pumping plant, or pumping-generating plant, cannot be completed on a single PO&M-59, -59A, or 59B report form, one or more continuation sheets (form PO&M-59C) shall be used. Figure E-3 is an example of a blank PO&M-59C report form.

Instructions for reporting are as follows:

1. **Powerplant** – Insert the powerplant name.
2. **Installed Capacity** – Insert the total installed generating capacity (in kilowatts [kW]) in service at the end of the reported month (including station service units).
3. **Project** – Insert the official name of the Project.
4. **Region** – The Reclamation geographical Region is represented by a numerical equivalent as identified below. Insert the Region’s number.
 - 1 – PN Region
 - 2 – MP Region
 - 3 – LC Region
 - 4 – UC Region
 - 6 – GP Region
5. **Facility** – Insert the appropriate code listed in FIST Volume 4-2, Power O&M Codes for ADP, for the powerplant being reported.
6. **Type** – This block contains a preprinted letter originally for ADP use P = Powerplant, U = Pumping Plant, and X = Pump-Generating Plant.
7. **Date** – Insert a four-digit abbreviation for the year and month, e.g., 1207 for July 2012 or 1211 for November 2012.

8. **Gross Generation** – Insert the kilowatt-hour (kWh) output during the month for all generators, including station service units. The plant unit generation must equal the total plant Gross Generation.
9. **Plant Auxiliary Use** – Insert the total energy used during the month for plant operation, whether supplied by main or station service units, or obtained from the outside system. It includes power used for plant lighting and operation of plant auxiliaries. Power used for synchronous condenser operation of the generating units to improve system voltage and to supply reactive power for system operations, should be charged to the power transmission system, not to production. Do not include any energy required for operating generating units as synchronous condensers in “plant use.”
10. **Net Generation** – Subtract the Plant Auxiliary Use from the Gross Generation to obtain Net Generation.
11. **Maximum Hourly Generation** – Insert the largest **total** generation (including station service generation) during any whole clock hour (e.g., between 1900 and 2000, not 1830 and 1930).
12. **Condenser Operation** – Insert total energy input (motoring energy used), if any, to generating units operated as synchronous condensers.
13. **Plant Factor** – A measure of plant performance during the month from the standpoint of energy production. Ratio (expressed in percent) of the Gross Generation for the month divided by the number of hours in the month and the installed capacity. (See NOTE at bottom of figure E-2 for an example of Plant Factor). Computation of this quantity is optional. Local awareness may be desirable.
14. **Utilization Factor** – A measure of plant performance during the month from the standpoint of capacity use. Ratio (expressed in percent) of the Maximum Hourly Generation to installed capacity. Computation of this quantity is optional. Local awareness may be desirable.
15. **Water for Generation** – Insert the quantity of water, in acre-feet (AF), passed through all the turbines for the month.
16. **Other Water Released Downstream** – Insert the quantity of water, in acre-feet, available for the Downstream generation of power, but was bypassed downstream (released or spilled) and not used for generation because of insufficient powerplant generating, capability lack of system load to use all water, or other reasons. Also include (with appropriate footnote) quantity of water released for any major local auxiliary use, such as operation of fish trap or ladder.

17. ***KWh Generation/AF*** – Computed as the ratio of Gross Generation (item 8) to Water for Generation (item 15) rounded to closest tenth. Calculate and insert number.
18. ***Elevations and Flow at Month End*** – Insert the forebay and tailrace water surface elevations, at the end of the Month measured to the nearest hundredth of a foot during the period of maximum plant generation on the last day of the reported month. Also insert the total release downstream (in cubic feet per second [cfs]) at the time of maximum plant generation, including other downstream releases (if any) that might have occurred simultaneously.
19. ***Water Factor*** – A measure of plant performance from the standpoint of water use. Ratio, expressed in percent, of Water for Generation (item 15) to the total water released (sum of items 15 and 16). Computation of this quantity is optional. Local awareness may be desirable.
20. ***Unit Service Record*** – This portion of the report shall be used for itemizing particular operating and maintenance information for each generating unit in the plant. Each event for each unit should be listed on a separate line, grouped first by unit designation, then chronologically by date and hour. If more than one outage occurred for a particular unit during the reported period, list first the **totals** for that unit, followed chronologically by individual entries on separate lines for each maintenance shutdown, whether scheduled or forced.
21. ***Unit Number*** – Insert the designated unit number, such as N7, 2, LS1.
22. ***Gross Generation*** – Insert the gross generation of each unit in the plant, including station service units. Where watthour meters with ratchets are provided, this quantity would be the difference between “OUT” meter readings at the end and beginning of the month. For meters without ratchets, the summation of reverse rotation (if any) for synchronous condenser operation should be determined and added to the indicated forward rotation of the meter. The sum of power generation by all units must equal the total plant Gross Generation (item 8).
23. ***Time Operated*** – The difference of the unit time-meter readings at the end and beginning of the reporting month if such meters are provided; otherwise, the reported figure should be the summation of the operating periods during which the unit was rotating during the month, from the time of starting to the time of shutdown as recorded on the plant log, regardless of whether the unit was running for test purposes, delivering power to the bus, motoring as a synchronous condenser, or providing system spinning reserve. Calculate and record the number in decimal hours, rounded to closest tenth (e.g., 412.3).

24. **Time Available** – The period during which a unit is in service or ready for service. This period must equal the total hours in the month minus all periods during which the unit was **not available** for operation. Calculate and record the number in hours and minutes (e.g., 483:06).
25. **Availability Factor** – Computed ratio of the Time Available (item 24) to the total hours in the month, expressed in percent, and rounded to the closest tenth of 1 percent. Calculate and record the number.
26. **Unit Starts** – Insert the number of times the unit was started during the month.
27. **Maintenance Information** – Entries in all columns under this general heading shall relate to unit outages or shutdowns **strictly** for maintenance reasons.

If no outages for maintenance occurred during the month for a unit, entries of **zero** should be made on the same line as the unit number in the four columns headed “Duration,” “Individual Outage,” “Total for Month,” and “Maintenance Factor” (items 31, 33, 34, and 35, respectively). (See entries for Unit 3 on sample form PO&M-59, figure E-2.)

If only one outage for maintenance occurred during the month for a unit, all entries should be made on the same line as the unit number. (See entries for Unit 1 on sample form PO&M-59, figure E-2.)

If two or more outages for maintenance occurred during the month for a unit, entries for “Total for Month” and “Maintenance Factor” should be made on the same line as the unit number. Entries for each individual outage should be made on successively following lines in chronological order. (See entries for Unit 2 on sample form PO&M-59, figure E-2.)

28. **Type** – Insert either an “F” or “S” to distinguish whether the outage was forced or scheduled.
29. **Day** – For each individual outage, insert a **two-digit** figure in chronological order to indicate the day of the month on which the outage occurred (e.g., 03 for the 3rd day or 27 for the 27th day). For an outage extending from the previous month, insert “01” in this column. (See entries for Unit 8 on sample form PO&M-59, figure E-2.)
30. **Time** – Insert a **four-digit** figure to indicate, to the closest minute, the time of day at which the outage occurred, measured on a 24-hour time basis (e.g., 0042 represents 12:42 a.m. or 1733 represents 5:33 p.m.).

For a prolonged outage extending from the preceding month, insert **four zeros** in this column. (See entries for Unit 8 on sample form PO&M-59, figure E-2.)

31. **Duration** – For each maintenance outage, indicate the total elapsed time in hours and minutes that the unit was out of service, measured from the time the outage began until the unit was either returned to service or made available for operation, whichever applied. This will include all nonwork times such as meals, nights, and weekend periods. Calculate and insert number.

Maintenance of power system facilities “outside the plant” (low voltage side of the step-up and beyond), which makes a generating unit unavailable for operation, should be reported in this column and should be described by appropriate notation in the column titled “Description of Maintenance or Forced Outage.” (See entries for Unit 2 for the 26th of the month at 0840 hours on sample form PO&M-59, figure E-2.)

NOTE: The POMTS list of “Cause Code Descriptions and Numbers” is used when identifying cause codes pertaining to generators and pumping-generators (item 36).

32. **Actual Maintenance Time** – Insert the time that maintenance work was **actually** being performed on the unit.
33. **Individual Outage** – For each outage, insert the time in hours and minutes that work **actually** was performed on the generating unit or essential auxiliaries. Do **not** include nonwork time such as meals, nights, or weekend periods.
34. **Total for the Month** – On the same line as the unit number, enter the **total** time for the month, in hours and minutes, that maintenance work was actually being performed on the unit. This quantity must equal the sum of entries in the preceding column for all maintenance outages of the unit during the month.
35. **Maintenance Factor** – A measure of maintenance performance on each generating unit. The factor is the ratio of the Total **Actual** Maintenance Time for the unit during the month (item 34) to the total hours in the month, expressed in percent, and rounded to the closest tenth of 1 percent. Calculate and insert the number.
36. **Reason Code** – The electronic Power Operations and Maintenance Tracking System (POMTS) list of “Cause Code Descriptions and Numbers” is used when identifying cause codes pertaining to generators and pumping-generators . The list is based on the Generating

Availability Data System (GADS) codes, as published by the North American Electric Reliability Corporation (NERC). (See entries on the sample form PO&M-59, figure E-2.) Insert the appropriate code.

37. ***Description of Maintenance or Forced Outage*** – Provide a brief description of the maintenance performed and the cause or reason for each forced outage.

MONTHLY REPORT OF POWER OPERATIONS - POWERPLANTS													
FORM-59 (Rev 2-2012) Bureau of Reclamation		PROJECT COLORADO RIVER STORAGE											
POWERPLANT GLEN CANYON		INSTALLED CAPACITY (KW) 1,288,000		CONDENSER OPERATION (KWH)		REG 4		FACILITY TYPE GC		DATE YR MO 1203			
GROSS GENERATION (KWH)		PLANT AUXILIARY USE (KWH)		NET GENERATION (KWH)		HOURLY GENERATION (KWH)		MAXIMUM GENERATION (KWH)		UTILIZATION FACTOR (%)			
412,075,000		950,639		411,124,361		1,093,000		1,327,000		84			
WATER FOR GENERATION (A.F.)		OTHER WATER RELEASED DOWNSTREAM (A.F.)		Kwh GENERATION/A.F.		FOREBAY (FT)		TAILRACE (FT)		TOTAL FLOW (CFS)			
843,050		0		488.0		3683.04		3138.63		14,514			
ELEVATIONS AND FLOW AT MONTH END													
UNIT SERVICE RECORD													
MAINTENANCE INFORMATION													
UNIT NO.	GROSS GENERATION (KWH)	TIME OPERATED (HRS)	TIME AVAILABLE (HR:MIN)	AVAILABILITY FACTOR (%)	UNIT STARTS	OUTAGES FOR MAINTENANCE			ACTUAL MAINTENANCE TIME			REASON CODE	DESCRIPTION OF MAINTENANCE OR FORCED OUTAGE
						T P E DAY	TIME	DURATION HRS:MIN	INDIVIDUAL OUTAGE HRS:MIN	TOTAL FOR MONTH HRS:MIN	Maintenance Factor (%)		
1	9,570,000	35.0	73:13	9.8	2	S 04	1113	670:47	198:10	198:10	26.6	9199	Annual maintenance and repair seal ring.
2	72,135,000	370.7	536:30	72.1	12	S 06	0837	99:05	34:25	54:20	7.3	3653	KIA change diff. relaying
3	50,255,000	415.2	744:00	100.0	19	S 26	0840	0:35	19:55			3620	Repair transformer oil cooler
4	74,270,000	677.5	744:00	100.0	11	F 27	1210	107:50	0	0	0	4550	Thrust bearing running hot
5	74,240,000	636.7	744:00	100.0	12	S 20	1143	3:46	3:46	2:32	2:32	7009	Turbine brg. oil reservoir chg
6	75,860,000	655.9	740:14	99.5	8	S 01	0000	744:00	128:00	128:00	17.2	4830	Rewind
7	55,745,000	549.0	744:00	100.0	9								
8	0	0	0	0	0								

NOTE: Glen Canyon Plant Factor for March = 43% (412,075,000/(744*1,288,000))=43

Submit Report Form to: Denver Office, Attention: 86-61600, P.O. Box 25007, Denver Federal Center, Denver, CO 80225-0007

Figure E-1. Blank PO&M-59 Report Form.

MONTHLY REPORT OF POWER OPERATIONS - POWERPLANTS												
POWERPLANT		INSTALLED CAPACITY (kW)		PROJECT		REG		DATE				
GLEN CANYON		1,288,000		COLORADO RIVER STORAGE		4		YR MO				
GROSS GENERATION (kWh)		PLANT AUXILIARY USE (kWh)		NET GENERATION (kWh)		HOURLY GENERATION (kWh)		UTILIZATION FACTOR (%)				
412,075,000		950,639		411,124,361		1,093,000		84				
WATER FOR GENERATION (A.F.)		OTHER WATER RELEASED DOWNSTREAM (A.F.)		Kwh GENERATION/A.F.		TAILRACE (FT)		TOTAL FLOW (CFS)				
843,050		0		488.0		3683.04		14,514				
UNIT SERVICE RECORD												
ELEVATIONS AND FLOW AT MONTH END												
FOREBAY (FT)												
3683.04												
TOTAL FLOW (CFS)												
14,514												
WATER FACTOR (%)												
100												
MAINTENANCE INFORMATION												
OUTAGES FOR MAINTENANCE				ACTUAL MAINTENANCE TIME				REASON * CODE		DESCRIPTION OF MAINTENANCE OR FORCED OUTAGE		
UNIT NO.	TIME OPERATED (hrs)	TIME AVAILABLE (hr:min)	AVAILABILITY FACTOR (%)	UNIT STARTS	DAY	TIME	DURATION (hrs:min)	INDIVIDUAL OUTAGE (hrs:min)	TOTAL FOR MONTH (hrs:min)	Maintenance Factor (%)		
1	9,570,000	73:13	9.8	2	S	04 1113	670:47	198:10	198:10	26.6	9199	Annual maintenance and repair seal ring.
2	72,135,000	536:30	72.1	12	S	06 0837	99:05	34:25	54:20	7.3	3653	KIA change diff. relaying
3	50,255,000	744:00	100.0	19	S	26 0840	0:35	19:55			3620	Repair transformer oil cooler
4	74,270,000	744:00	100.0	11	F	27 1210	107:50				4550	Thrust bearing running hot
5	74,240,000	744:00	100.0	12	S	20 1143	3:46	3:46	2:32	2:32	7009	Turbine brg. oil reservoir chg
6	75,860,000	655:9	99.5	8	S	01 0000	744:00	128:00	128:00	17.2	4830	Rewind
7	55,745,000	549:0	100.0	9	S							
8	0	0	0	0	S							

NOTE: Glen Canyon Plant Factor for March = 43% (412,075,000/(744*1,288,000))=43

Submit Report Form to: Denver Office, Attention: 86-61600, P.O. Box 25007, Denver Federal Center, Denver, CO 80225-0007

Figure E-2. Completed PO&M-59 Report Form.

Appendix E-2 – Instructions for Completing Form PO&M-59A, “Monthly Report of Power Operations – Pumping Plants”

Figure E-3 is a blank PO&M-59A Report form, and Figure E-4 is an example of a properly completed PO&M-59A Report form. One report is to be prepared for each pumping plant with a total installed pump-motor capacity of 15,000 horsepower or greater, covering operations each calendar month. The report period starts at midnight (0000) on the first and ends at midnight on the last day of the month (2400). Daylight savings time changes (i.e., 23-hour and 25-hour day) are included in the reports for the respective month in which the time change occurs.

NOTE: In the event the “Unit Service Record” part of the report for an individual powerplant, pumping plant, or pumping-generating plant cannot be completed on a single PO&M-59, -59A, or 59B report form, one or more continuation sheets (form PO&M-59C) shall be used. Figure E-3 is an example of a blank PO&M-59C report form.

Instructions for reporting are as follows:

1. ***Pumping Plant*** – Official name of the pumping plant, followed by total installed pump-motor capacity (in horsepower) in service at the end of the reported month, followed by the official name of the project.
2. ***Installed Capacity*** – The pumping plant installed capacity in horsepower (hp).
3. ***Project*** – The name of the Reclamation Authorized Project.
4. ***Region*** – The Reclamation geographical Region is represented by a numerical equivalent as identified below. Insert the Region’s number.

- 1 – PN Region
- 2 – MP Region
- 3 – LC Region
- 4 – UC Region
- 6 – GP Region

5. **Facility** – Insert the appropriate code listed in FIST Volume 4-2, Power O&M Codes for ADP, for the pumping plant being reported.
6. **Type** – This block contains a preprinted letter originally for ADP use P = Powerplant; U = Pumping Plant; and X = Pump-Generating Plant.
7. **Date** – Insert a four-digit abbreviation for the year and month (e.g., 1207 for July 2012 or 1211 for November 2012).
8. **Pumping Energy Used** – Insert the total energy used during the month by all units for pumping water. Also, see item 17 regarding identification of energy used, if any, for operation of units as synchronous condensers.
9. **Plant Auxiliary Use** – Insert the total energy used during the month for plant operation, whether supplied by main or station service units, or obtained from the outside system. It includes power used for plant lighting and operation of plant auxiliaries. Do not include any energy required for operating pumping units as synchronous condensers in “plant use.”
10. **Maximum Pumping Demand** – Insert the greatest power demand, in kW, occurring during the monthly reporting period.
11. **Water Pumped** – Insert the total quantity of water, in acre-feet, pumped by all the pumping units of the plant during the month. If water-measuring devices are installed at the plant, these should be used to establish the amount of water pumped during the month; otherwise the quantity should be estimated from the head-discharge performance curves of the pumps as based on manufacturer’s and plant test data. Estimates may be made against kilowatthours of pumping energy used when the head-energy discharge relationship has been established. Checks should be made against discharge channel stream gauge flow readings or discharge-conduit flow meter readings, if practicable.
12. **KWh Pumping/AF** – Is the ratio of the Pumping Energy Used for the month (item 11) to the quantity of water pumped (item 8), rounded to the closest tenth. Calculate and insert the number.
13. **Average Pumping Head** – The average pumping head to be reported each month is the difference in feet between the **average** discharge elevation and the **average** intake elevation. Calculate and insert the number.

14. ***Intake and Discharge Elevations at Month End*** – Insert the water surface elevations of the intake bay or channel and of the discharge bay or channel, measured to the nearest hundredth of a foot at the time of maximum demand on the pumping plant during the last day of the reported month.
15. ***Unit Service Record*** –This portion of the report shall be used for itemizing particular operating and maintenance information for each pumping unit in the plant. Each event for each unit should be listed on a separate line, grouped first by unit designation, then chronologically by date and hour. If more than one outage occurred for a particular unit during the reported period, list first the **totals** for that unit, followed chronologically by individual entries on separate lines for each maintenance shutdown, whether scheduled or forced.
16. ***Unit Number*** – Insert the designated unit number, such as 1, P-5, etc.
17. ***Pumping Energy Used*** – Insert the total energy used during the month by each unit for pumping. This quantity would be the difference between watt-hour meter readings for each unit at the end and beginning of the reported month. The sum of the quantities in this column must equal the total plant Pumping Energy Used (item 8).

An exception would occur whenever a unit was operated unloaded as a synchronous condenser. In that event, the energy used for condenser operation should be deducted, totaled for all units, and indicated in a footnote at the bottom of the report. (See sample form PO&M-59A, figure E-4).
18. ***Time Operated*** – The difference of the unit time-meter readings at the end and beginning of the reporting month where such meters are provided. Where no meters are provided, the reported figure should be the summation of the operating periods during which the unit was rotating during the month, from the time of starting to the time of shutdown as recorded on the plant log, regardless of whether the unit was running for test purposes, actually pumping, or operating unloaded as a synchronous condenser to provide reactive-power and/or voltage support to the power system. Record the data in decimal hours, rounded to closest tenth (e.g., 716.4).
19. ***Time Available*** – The period during which a unit is in service or ready for service. This period must equal the total hours in the month minus all periods during which the unit was **not available** for operation. Record the data in hours and minutes (e.g., 716:54).

20. **Availability Factor** – Computed ratio of the Time Available (item 19) to the total hours in the month, expressed in percent, and rounded to the closest tenth of 1 percent. Calculate and insert the number.
21. **Unit Starts** – Insert the number of times the unit was started during the month.
22. **Maintenance Information** – Entries in all columns under this general heading shall relate to unit outages or shutdowns **strictly** for maintenance reasons.

If no outages for maintenance occurred during the month for a unit, entries of **zero** should be made on the same line as the unit number in the four columns headed “Duration,” “Individual Outage,” “Total for Month,” and “Maintenance Factor” (items 26, 28, 29, and 30, respectively). (See entries for Unit 1 on sample form PO&M-59A, figure E-4.)

If only one outage for maintenance occurred during the month for a unit, all entries should be made on the same line as the unit number. (See entries for Unit 2 on sample form PO&M-59A, figure E-4.)

If two or more outages for maintenance occurred during the month for a unit, entries for “Total for Month” and “Maintenance Factor” should be made on the same line as the unit number. Entries for each individual outage should be made on successively following lines in chronological order. (See entries for Unit 3 on sample form PO&M-59A, figure E-4.)

23. **Type** – Insert either an “F” or “S” to distinguish whether the outage was forced or scheduled.
24. **Day** – For each individual outage, insert a **two-digit** figure in chronological order to indicate the day of the month on which the outage occurred (e.g., 03 for the 3rd day, or 27 for the 27th day). For an outage extending from the previous month, insert “01” in this column. (See entries for Unit 7 on sample form PO&M-59A, figure E-4.)
25. **Time** – Insert a **four-digit** figure to indicate, to the closest minute, the time of day at which the outage occurred, measured on a 24-hour time basis (e.g., 0042 represents 12:42 a.m. or 1733 represents 5:33 p.m.).

For a prolonged outage extending from the preceding month, insert **four zeros** in this column. (See entries for Unit 7 on sample form PO&M-59A, figure E-4.)

26. **Duration** – For each maintenance outage, indicate the total elapsed time in hours and minutes that the unit was out of service, measured from the time the outage began until the unit was either returned to service or

made available for operation, whichever applied. This will include all nonwork times such as meals, nights, and weekend periods.

Maintenance of power system facilities “outside the plant” (low voltage side of the step-up and beyond), which makes a pumping unit unavailable for operation, should be reported in this column and should be described by appropriate notation in the column titled “Description of Maintenance or Forced Outage.” (See entries for Unit 3 for the 23th of the month at 0852 hours on sample form PO&M-59A, figure E-4.)

27. **Actual Maintenance Time** – Insert the time that maintenance work was **actually** being performed on the unit.
28. **Individual Outage** – For each outage, insert the time in hours and minutes that work **actually** was performed on the pumping unit or essential auxiliaries. Do **not** include nonwork time such as meals, nights, or weekend periods.
29. **Total for the Month** – On the same line as the unit number, enter the **total** time for the month, in hours and minutes, that maintenance work was actually being performed on the unit. This quantity must equal the sum of entries in the preceding column for all maintenance outages of the unit during the month.
30. **Maintenance Factor** - A measure of maintenance performance on each pumping unit. The factor is the ratio of the Total **Actual** Maintenance Time for the unit during the month (item 29) to the total hours in the month, expressed in percent, and rounded to the closest hundredth of 1 percent. Calculate and insert number.
31. **Description of Maintenance or Forced Outage** – Provide a brief description of the maintenance performed, and the cause or reason for each forced outage.

MONTHLY REPORT OF POWER OPERATIONS - PUMPING PLANTS									
PUMPING PLANT					PROJECT				
BUREAU OF RECLAMATION									
P.O. 59A (Rev 2-2012)									
BUREAU OF RECLAMATION									
PUMPING PLANT									
INSTALLED CAPACITY (hp) (2)									
PROJECT (3)									
REG (4)									
FACILITY (5)									
TYPE (6)									
DATE YR MO (7)									
PUMPING ENERGY USED (kWh) (8)									
PLANT AUXILIARY USE (kWh) (9)									
MAXIMUM DEMAND (kWh) (10)									
WATER PUMPED (A.F.) (11)									
KWh PUMPING/A.F. (12)									
AVERAGE PUMPING HEAD (FT.) (13)									
ELEVATIONS AT MONTH END									
INTAKE (FT.) (14)									
DISCHARGE (FT.) (14)									
UNIT SERVICE RECORD (15)									
MAINTENANCE INFORMATION (22)									
ACTUAL MAINTENANCE TIME (32)									
OUTAGES FOR MAINTENANCE									
TYPICAL									
DURATION (hrs:min) (26)									
INDIVIDUAL OUTAGE (hrs:min) (28)									
TOTAL FOR MONTH (hrs:min) (29)									
MAINTENANCE FACTOR (%) (30)									
DESCRIPTION OF MAINTENANCE OR FORCED OUTAGE									
UNIT NO. (16)									
GROSS GENERATION (kWh) (17)									
TIME OPERATED (hrs) (18)									
TIME AVAILABLE (hr:min) (19)									
AVAILABILITY FACTOR (%) (20)									
UNIT STARTS (21)									
UNIT SERVICE RECORD (15)									
Submit Report Form to: Denver Office, Attention: 86-61600, P.O. Box 25007, Denver Federal Center, Denver, CO 80225-0007									

Figure E-3. Blank PO&M-59A Report Form.

PO&M-59A (Rev 2-2012) Bureau of Reclamation		MONTHLY REPORT OF POWER OPERATIONS - PUMPING PLANTS										REG	FACILITY	TYPE	DATE YR MO
PUMPING PLANT CLEMENT VALLEY		INSTALLED CAPACITY (hp) 135,00 hp		PROJECT NEWMANS		REG		FACILITY		TYPE		DATE			
PUMPING ENERGY USED (kWh) a/		PLANT AUXILIARY USE (kWh)		MAXIMUM DEMAND (kWh)		WATER PUMPED (A.F.)		kWh PUMPING/A.F.		AVERAGE PUMPING HEAD (FT.)		ELEVATIONS AT MONTH END INTAKE (FT.)		DISCHARGE (FT.)	
50,800,700		1,473,000		90,000		231,724		219.2		192.1		25.05		220.40	
UNIT SERVICE RECORD															
MAINTENANCE INFORMATION															
UNIT NO.	GROSS GENERATION (kWh)	TIME OPER- ATED (hrs)	TIME AVAIL- ABLE hr:min	AVAIL- ABILITY FACTOR (%)	UNIT STARTS	OUTAGES FOR MAINTENANCE			ACTUAL MAINTENANCE TIME			MAINTENANCE FACTOR (%)	DESCRIPTION OF MAINTENANCE OR FORCED OUTAGE		
						DAY	TIME	DURATION hrs:min	INDIVID- UAL OUTAGE hrs:min	TOTAL FOR MONTH hrs:min					
1	10,880,500	716.4	720:00	100.0	2			0	0	0	0	0			
2	10,411,100	716.4	716:54	99.6	1	S	13	0800	3:06	3:06	3:06	0.43	Change bearing oil.		
3	10,305,100	708.2	713:43	99.1	3	S	12	0800	3:21	3:21	3:21	0.45	Change bearing oil.		
4	5,986,800	393.7	715:28	99.4	23	F	04	0832	1:36	1:36	4:32	.60	Gland maintenance.		
5	4,367,400	287.8	692:50	96.2	20	S	04	1430	2:56	2:56	10:50	1.50	Change bearing oil.		
6	8,849,800	582.2	716:42	99.5	3	S	12	1230	3:18	3:18	3:18	0.44	Change bearing oil.		
7	0	0	0	0	0	S	01	0000	720:00	160:00	160:00	22.22	Undergoing major overhaul.		
													a/ Does not include 23,900 kWh used for condenser operation.		

Submit Report Form to: Denver Office, Attention: 86-61600, P.O. Box 25007, Denver Federal Center, Denver, CO 80225-0007

Figure E-4. Completed PO&M-59A Report Form.

Appendix E-3 – Instructions for Completing Form PO&M-59B, “Monthly Report of Power Operations – Pumping-Generating Plants”

Figure E-5 is a blank PO&M-59B Report form, and figure E-6 is an example of a properly completed PO&M-59B Report form. One report is to be prepared for each calendar month for each plant where combination activities of generating electric power and pumping major quantities of water through the use of electric power can take place. This includes installations such as Grand Coulee, Mount Elbert Pumping-Generating Plants, the O’Neill Pumping Plant (since generation may occur occasionally at this installation), and the third unit in the Flatiron Power and Pumping Plant. For San Luis and O’Neill Plants, where responsibilities for certain functions are shared between the United States and the State of California, two copies of this report shall be prepared for each plant: one presenting total operating information for the plant, including the unit service record portion and the second indicating only the United States’ share of generation (gross and net), pumping, water amounts, etc.

The report period starts at midnight (0000) on the first and ends at midnight on the last day of the month (2400). Daylight savings time changes (i.e., 23-hour and 25-hour day) are included in the reports for the respective month in which the time change occurs.

NOTE: In the event the “Unit Service Record” part of the report for an individual powerplant, pumping plant or pumping-generating plant cannot be completed on a single PO&M-59, -59A, or 59B report form, one or more continuation sheets (form PO&M-59C) shall be used. Figure E-3 is an example of a blank PO&M-59C report form.

Instructions for reporting are as follows:

1. ***Pumping-Generating Plant*** – Insert the official name of the pumping plant.
2. ***Installed Capacity*** – Insert the dual rating of total installed pump-motor capacity in horsepower (hp) and generating capacity in kilowatts (kW) in service at the end of the reported month.
3. ***Project*** – Insert the official name of the Project.
4. ***Region*** – The Reclamation geographical Region is represented by a numerical equivalent as identified below. Insert the Region’s number.

- 1 – PN Region
 - 2 – MP Region
 - 3 – LC Region
 - 4 – UC Region
 - 6 – GP Region
5. **Facility** – Insert the appropriate code listed in FIST Volume 4-2, “Power O&M Codes for ADP,” for the pumping plant being reported.
 6. **Type** – This block contains a preprinted letter originally for ADP use P=Powerplant; U=Pumping Plant; and X = Pump-Generating Plant.
 7. **Date** – Insert a four-digit abbreviation for the year and month (e.g., 1207 for July 2012 or 1211 for November 2012).
 8. **Gross Generation** –Insert the total kWh output for all units during the month while operating as generating units. The plant unit generation must equal the total plant Gross Generation.
 9. **Plant Auxiliary Use** – Insert the total energy used during the month for plant operation, whether supplied by the units while generating or obtained from the outside system. It includes power used for plant lighting and operation of plant auxiliaries. Do not include any energy required for operating pumping units as synchronous condensers in “plant use.”
 10. **Net Generation** – Energy delivered to the outside system during periods of generation. (On reports for Mount Elbert Plant the Sangre De Cristo energy is not used in the calculation. On reports for San Luis and O’Neill Plants covering only the United State’s portion of plant information, this item should be **only** the Reclamation portion of delivery to the PGE system.)
 11. **Maximum Hourly Generation** – Insert the largest **total** generation (in kWh) during any whole clock hour (e.g., between 1900 and 2000, not 1830 and 1930).
 12. **Water for Generation** – Insert the quantity of water, in acre-feet, used during the month for energy generation at the plant. Water-measuring devices should be used in establishing the amount of water used for power generation, if available; otherwise, provide the best estimate by using performance curves or other acceptable methods.
 13. **KWh Generation/AF** – Computed as the ratio of Gross Generation (item 8) to Water for Generation (item 12) rounded to closest tenth. Calculate and insert number.

14. ***Pumping Energy Used*** – Insert the total energy (in kWh) used during the month by all units for actual pumping of water. Also see item 22 regarding identification of energy used, if any, for operation of units as synchronous condensers.
15. ***Maximum Pumping Demand*** – Insert the greatest power demand, in kW, occurring during pumping operations for the monthly reporting period.
16. ***Water Pumped*** – Insert the total quantity of water, in acre-feet, pumped by all units during the month. Water-measuring devices should be used in establishing the amount of water pumped during the month, if available; otherwise, the quantity should be estimated from the head-discharge performance curves of the pumps as based on manufacturer's and plant test data or other acceptable methods.
17. ***KWh Pumping/AF*** – Computed as the ratio of the Pumping Energy Used for the month (item 14) to the quantity of water pumped (item 16), rounded to the closest tenth. Calculate and insert the number.
18. ***Upper and Lower Pond (Forebay and Tailrace) Water Elevations at Month End*** – Insert the upper and lower (forebay and tailrace) water surface elevations, measured to the nearest hundredth of a foot, during the period of maximum plant generation on the last day of the reporting month. If the plant was not used for generating energy during the last day of the month, report elevations at a time of maximum pumping demand.
19. ***Unit Service Record*** – This portion of the report shall be used for itemizing particular operating and maintenance information for each unit in the plant. Each event (or totalization of data) for each unit should be listed on a separate line, grouped first by unit designation, then chronologically by date and hour. If more than one outage occurred for a particular unit during the reported period, list first the **totals** for that unit, followed chronologically by individual entries on separate lines for each maintenance shutdown, whether scheduled or forced.
20. ***Unit Number*** – Insert the designated unit number, such as 1, P/G-7, etc.
21. ***Mode*** – This column indicates the unit's type of operation (i.e., generating or pumping). Insert the letter "G" for generating or the letter "P" for pumping.
22. ***Power Generated or Pumping Energy Used*** – Insert the gross generation of each unit in the plant during the month, while operating as a generator, on the line identified with the letter "G." Where watthour meters with ratchets are provided, this quantity for each unit would be the difference between "OUT" meter readings at the end and beginning

of the month. For meters without ratchets, it will be necessary to determine this quantity from meter readings at the beginning and end of each period of generator operation during the month. If no generation occurred for a unit, insert "O." The sum of the quantities in designated "G" in this column must equal the total plant Gross Generation (item 8).

Insert the total energy used while operating as a pumping unit, during the month, on the line identified with the letter "P." Where watt-hour meters with ratchets are provided, this quantity for each unit would be the difference between "IN" meter readings at the end and beginning of the month. For meters without ratchets, it will be necessary to determine this quantity from meter readings at the beginning and end of each period of pumping operation during the month. If no pumping occurred for a unit, insert "O." The sum of the quantities designated "P" in this column must equal the total plant Pumping Energy Used (item 14).

An exception would occur if a unit was operated unloaded as a synchronous condenser. In that event, the energy used for condenser operation should be deducted, totaled for all units, and indicated in a footnote at the bottom of the report. (See sample form PO&M-59B, figure E-6).

23. ***Time Operated (Generator run time)*** – The difference of the unit time-meter readings at the end and beginning of the reporting month where such meters are provided. Where no meters are provided, the reported figure should be the summation of the periods during which the unit was rotating during the month, while in **generate mode** from the time of starting to the time of shutdown as recorded on the plant log, regardless of whether the unit was online, offline, running for test purposes, generating, or operating unloaded as a synchronous condenser to provide reactive power and/or voltage support to the power system. Record the data in decimal hours, rounded to closest tenth (e.g., 380.3, on the same line that contains the generation data for the unit [G line]).
24. ***Time Operated (Pump run time)*** – Where no meters are provided, the reported figure should be the summation of the periods during which the unit was rotating during the month, while in **pump mode** from the time of starting to the time of shutdown as recorded on the plant log, regardless of whether the unit was online, offline, running for test purposes or pumping. Record the data in decimal hours, rounded to closest tenth (e.g., 214.7, on the same line that contains the pumping data for the unit [P line]). (See sample form PO&M-59B, figure E-6).
24. ***Time Available*** – The period during which a unit is in service or ready for service. This period must equal the total hours in the month minus all periods during which the unit was not available for operation. (See sample form PO&M-59B, figure E-6).

Record the data in hours and minutes (e.g., 730:33, on the same line that contains the generation data for the unit).

EXCEPTION: If a forced outage occurs that prevents the pump from being started in pump mode but does not prevent the generator from being started in generate mode, the pump forced outage hours will not be deducted from the generator total time available. Insert a footnote in the “Time Available” column next to the recorded time available, on the “G” line, and insert a statement “does not affect generate mode” following the reason for the forced outage, in the “Description of Maintenance or Outage” column.

(See P/G-3 entry on sample form PO&M-59B, figure E-6).

25. **Availability Factor** – Computed ratio of the Time Available (item 24) to the total hours in the month, expressed in percent, and rounded to the closest tenth of 1 percent. Calculate and insert the number on the same line that contains the generation data.
26. **Unit Starts** – Insert the total number of times the unit was started in “generate” mode on the same line that contains the generation data, during the month. Insert the total number of times the unit was started in “pump” mode on the same line that contains the pumping data, during the month.
27. **Maintenance Information** – Entries in all columns under this general heading shall relate to unit outages or shutdowns **strictly** for maintenance reasons.

If no outages occurred during the month for a unit, entries of **zero** should be made on the same line that contains the generation data (G line), in the four columns headed “Duration,” “Individual Outage,” “Total for Month,” and “Maintenance Factor” (items 31, 33, 34, and 35, respectively). (See entries for P/G-2 on sample form PO&M-59B, figure E-6.)

If only one scheduled outage occurred during the month for a unit, all entries should be made on the same line that contains the generation data (G line) in the four columns headed “Duration,” “Individual Outage,” “Total for Month,” and “Maintenance Factor.”

If two or more **scheduled** outages occurred during the month for a unit, entries for “Total for Month” and “Maintenance Factor” should be made on the same line that contains the generation data (G line) in the four columns headed “Duration,” “Individual Outage,” “Total for Month,” and “Maintenance Factor.” Entries for each individual outage should be

made on successively following lines in chronological order. (See entries for P/G-3 on sample form PO&M-59B, figure E-6.)

Forced outages are documented on the unit line associated with the unit mode of operation at the time the forced outage occurred; thus, data pertaining to forced outages that occurred when the unit was generating would be documented on the same line that contains the generation data (G line), and data pertaining to forced outages that occurred when the unit was pumping would be documented on the same line that contains the pumping data (P line).

If two or more **forced** outages occurred during the month for a unit, entries for “Total for Month” and “Maintenance Factor” should be made on the same line that identifies the mode of operation (G or P line) in the four columns headed “Duration,” “Individual Outage,” “Total for Month,” and “Maintenance Factor.” Entries for each individual forced outage should be made on successively following lines in chronological order. (See entries for P/G-3 on sample form PO&M-59B, figure E-6.)

28. **Type** – Insert either an “F” or “S” to distinguish whether the outage was forced or scheduled.
29. **Day** – For each individual outage, insert a **two-digit** figure in chronological order to indicate the day of the month on which the outage occurred (e.g., 03 for the 3rd day, or 27 for the 27th day). For an outage extending from the previous month insert “01” in this column. (See entries for P/G-3 on sample form PO&M-59B, figure E-6.)
30. **Time** – Insert a **four-digit** figure to indicate, to the closest minute, the time of day at which the outage occurred, measured on a 24-hour time basis (e.g., 0042 represents 12:42 a.m. or 1802 represents 6:02 p.m).

For a prolonged outage extending from the preceding month, insert **four zeros** in this column. (See entries for P/G-2 on sample form PO&M-59B, figure E-6.)

31. **Duration** – For each outage, indicate the total elapsed time in hours and minutes that the unit was out of service, measured from the time the outage began until the unit was either returned to service or made available for operation, whichever applied. This will include all nonwork times such as meals, nights, and weekend periods.

Maintenance of power system facilities “outside the plant” (low voltage side of the step-up and beyond), which makes a unit unavailable for operation, should be reported in this column and should be described by appropriate notation in the column titled “Description of Maintenance or Forced Outage.”

NOTE: The POMTS list of “Cause Code Descriptions and Numbers” is used when identifying cause codes pertaining to generators and pumping-generators (item 36).

(See entries for P/G-3 on sample form PO&M-59B, figure E-6.)

32. **Actual Maintenance Time** – Insert the time that maintenance work was **actually** being performed on the unit.
33. **Individual Outage** – For each outage, insert the time in hours and minutes that work **actually** was performed on the unit or essential auxiliaries. Do **not** include nonwork time such as meals, nights, or weekend periods.
34. **Total for the Month** – On the same line as the unit number, enter the **total** time for the month, in hours and minutes, that maintenance work was **actually** being performed on the unit. The lines must equal the sum of entries in the preceding column for all maintenance outages of the unit during the month.
35. **Maintenance Factor** – A measure of maintenance performance on each unit. The factor is the ratio of the Total **Actual** Maintenance Time for the unit during the month (item 34) to the total hours in the month, expressed in percent and rounded to the closest hundredth of 1 percent. Calculate and insert number.
36. **Reason Code** – The electronic POMTS list of “Cause Code Descriptions and Numbers” is used when identifying cause codes pertaining to generators and pumping-generators. The list is based on the Generating Availability Data System (GADS) codes, as published by the North American Electric Reliability Corporation (NERC). (See entries on the sample form PO&M-59, figure E-6.) Insert the appropriate code.
37. **Description of Maintenance or Forced Outage** – Provide a brief description of the maintenance performed and the cause or reason for each forced outage.

MONTHLY REPORT OF POWER OPERATIONS - PUMPING-GENERATING PLANTS															
PO&M-59B (Rev 2-2012) Bureau of Reclamation PUMPING-GENERATING PLANT (1)															
INSTALLED CAPACITY (hp-kW) (2)															
PROJECT (3)															
REG (4)															
FACILITY (5)															
TYPE (6)															
DATE YR MO (7)															
GROSS GENERATION (kW)		PLANT AUXILIARY USE (kW)		NET GENERATION (kW)		HOURLY GENERATION (kW) (11)		MAXIMUM GENERATION (kW) (12)							
WATER FOR GENERATION (A.F.) (13)															
PUMPING ENERGY USED (kW)		MAX PUMPING DEMAND (kW)		WATER PUMPED (A.F.) (16)		KWH PUMPING/A.F.F. (17)		ELEVATIONS AND FLOW AT MONTH END UPPER POND (FT.) LOWER POND (FT.) (18)							
(14)															
UNIT SERVICE RECORD (19)															
MAINTENANCE INFORMATION (27)															
UNIT NO.	MODE	POWER GENERATED OR PUMPING ENERGY USED (kW)	TIME OPERATED (hrs)	TIME AVAILABLE (hr:min)	AVAILABILITY FACTOR (%)	UNIT STARTS	OUTAGES FOR MAINTENANCE			ACTUAL MAINTENANCE TIME (32)			DESCRIPTION OF MAINTENANCE OR FORCED OUTAGE		
							TYPE	DAY	TIME	DURATION	INDIVIDUAL OUTAGE	TOTAL FOR MONTH		MAINTENANCE FACTOR	* REASON CODE
(20)	(21)	(22)	(23)	(24)	(25)	(26)	(28)	(29)	(30)	(31)	(33)	(34)	(35)	(36)	(37)

Figure E-5. Blank PO&M-59B Report Form.

MONTHLY REPORT OF POWER OPERATIONS - PUMPING-GENERATING PLANTS															
PO&M-59B (Rev 2-2012)		Bureau of Reclamation		INSTALLED CAPACITY (hp-kw)		PROJECT		REG		DATE					
PUMPING-GENERATING PLANT		Custer Butte		143,000 hp -100,000 kw		Neumans		1		1203					
GROSS GENERATION (kwh)		PLANT AUXILIARY USE (kwh)		NET GENERATION (kwh)		HOURLY GENERATION (kwh)		MAXIMUM GENERATION (kwh)		Water for generation (A.F.)					
13,005,100		87,840		12,917,260		102,500		15,420		843.4					
PUMPING ENERGY USED (kwh)		MAX PUMPING DEMAND (kw)		WATER PUMPED (A.F.)		kwh PUMPING/A.F.		ELEVATIONS AND FLOW AT MONTH END		UPPER POND (FT.)					
18,697,100		93,600		15,430		1211.7		1,988.75		1,007.50					
UNIT SERVICE RECORD															
MAINTENANCE INFORMATION															
UNIT NO.	MODE	POWER GENERATED OR PUMPING ENERGY USED (kwh)	TIME OPERATED (hrs)	TIME AVAILABLE (hr:min)	AVAILABILITY FACTOR (%)	UNIT STARTS	OUTAGES FOR MAINTENANCE			ACTUAL MAINTENANCE TIME			REASON CODE	DESCRIPTION OF MAINTENANCE OR FORCED OUTAGE	
							T Y E	D U R A T I O N	T I M E	INDIVIDUAL OUTAGE	TOTAL FOR MONTH	MAINTENANCE FACTOR (%)			
P/G-1	G	6,501,300	380.3	744:00	100.0	27									
	P	9,346,500	214.7	---	---	26									
P/G-2	G	0	0	0	0	0	S	01	00:00	744:00	162:00	162:00	21.77	4831	Unit annual maintenance.
	P	0	0	---	---	0									
P/G-3	G	6,503,800	390.4	729:02 ^{1/2}	97.5	32	S	05	12:00	3:13	3:13	15:58	2.10	7009	Replace turbine bearing oil pump.
							F	11	08:18	1:05	1:05			4540	Replace and adjust slip ring brush.
							F	16	11:00	2:30	2:00			4590	Repair unit brake system.
							S	18	14:00	4:00	4:00			4750	Calibrate speed changer setting.
	P	9,350,600	250.2	---	---	20	F	08	05:03	4:10	3:40			7141	Pump not loading - gate limit problem.
							F	21	18:02	2:40	2:00			7299	Pump static start problems - ^{1/2} does not affect generate mode.
															^{1/2} Does not include 23,900 kwh used for condenser operation.

Figure E-6. Completed PO&M-59B Report Form.

Appendix E-4 – Instructions for Completing Form PO&M-59C, “Monthly Report of Power Operations – Continuation Sheet”

Figure E-7 is a blank sample of form PO&M-59B Report. In the event the unit service record part of the report for an individual powerplant, pumping plant, or pumping-generating plant cannot be completed on a single sheet of form PO&M-59, -59A, or 59B, respectively, one or more continuation sheets (form PO&M-59C) shall be used. Instructions for reporting under the various headings, in the sequence in which they appear on the forms are as follows:

1. **PO&M-59__** – Leave this space blank if the sheet is being used for continuation of a powerplant report; insert the letter “A” or “B” if being used for continuation of a pumping plant or a pumping-generating plant report, respectively.
2. **Plant** – Insert the official name of the specific facility (powerplant, pumping plant, or pumping-generating plant) for which the continuation sheet is being used.
3. **Region** – Insert the same Region number appearing on sheet 1 of the report.
4. **Facility** – Insert the same code appearing on sheet 1 of the report.
5. **Type** – Insert the same letter as used on sheet 1 of the report (P = Powerplant; U = Pumping Plant; and X = Pump-Generating Plant).
6. **Date** – Insert the same date as used on sheet 1 of the report.
7. **Unit Service Record** – Continue entries using the same instructions for forms PO&M-59, -59A- or 59B, whichever are applicable.

Appendix E-5 – Instructions for Completing Form PO&M-62, “Monthly Report of Transmission System Outages”

Figure E-8 is a blank PO&M-62 Report form, and figure E-9 (sheets 1 and 2) is an example of a properly completed PO&M-62 Report form. One report is to be prepared for each operating area, covering all transmission system outages in the area during the reported month.

The report period starts at midnight (0000) on the first and ends at midnight on the last day of the month (2400). Daylight savings time changes (i.e., 23-hour and 25-hour day) are included in the reports for the respective month in which the time change occurs. Instructions for reporting are as follows:

1. **Operating Area** – Insert the name of the operating area.
2. **Month and Year** – Insert the month and year of the report.
3. **Region** – The Reclamation geographical Region is represented by a numerical equivalent as identified below. Insert the Region’s number.
 - 1 – PN Region
 - 2 – MP Region
 - 3 – LC Region
 - 4 – UC Region
 - 6 – GP Region
4. **Date** – Insert a four-digit abbreviation for the year and month (e.g., 1207 for July 2012 or 1211 for November 2012).
5. **Day** – For each individual outage, insert a **two-digit** figure in chronological order to indicate the day of the month on which the outage occurred (e.g., 03 for the 3rd day, or 27 for the 27th day).
6. **Time** – Insert a **four-digit** figure to indicate, to the closest minute, the time of day at which the outage occurred, measured on a 24-hour time basis (e.g., 0042 represents 12:42 a.m. or 1802 represents 6:02 p.m). Events are listed chronologically for the day. Individual outages will be separated by a horizontal line, before starting entries for the next outage. (See entries for day 04 on sample for PO&M-62, Sheet 1 of 2, figure E-9,.)

For a prolonged outage extending from the preceding month, insert **four zeros** in this column. For an outage extending from the previous month, insert “01” in the “Day” column on the **first** line of the report for the new month. In subsequent columns, repeat all information that appeared for the outage entry on the previous month’s report, **except** for the “Duration”

column. In the “Duration” column, report only the extent of the outage during the current month. (See entries for day 01 at 0000 on sample form PO&M-62, Sheet 1 of 2, figure E-9.)

If entries for any single outage are so extensive as to require continuation on a following page, indicate “continued on next page” at the bottom of the one sheet, and “continued from preceding page” at the top of the next sheet. On the first line of data at the top of the following page, **repeat** outage information in the columns headed “Day,” “Time,” “Type of Fault,” “Customer Service Interrupted,” “Outage Type” and “Outage Cause or Reason” (items 5, 6, 19, 20, 22, and 23, respectively).

For the condition of a prior breaker and/or relay operation observed during periodic rounds of inspection at an unattended station, insert the date and time of inspection or relay resetting, and provide an explanation in the “Remarks” column. (See entries for day 12 on sample for PO&M-62, Sheet 2 of 2, figure E-9.) Should an inspection disclose several such operations since the last previous inspection, for example, if a total of eight operations occurred, make one entry then on the **next line** place and **asterisk (*) in both** the “Day” and “Time” columns, followed by the notation “Repeat data on line above eight times.” (See entries for day 14 on sample form PO&M-62 Sheet 2 of 2, figure E-9.)

7. **Station, Line, Line-Section, or Tap** – Information such as station designation, type of equipment, voltage, etc., are identified in this section of the report as follows:
8. **Name or Terminals** – For an outage at a station; or of a transmission line; section of a line; radial line or tap line; insert the **facility code** of the station or terminals of the line involved, in this column, using approved code designations appearing in FIST Volume 4-2, Power O&M Codes for ADP. When identifying a line by its two terminals, identify the terminal end closest to the station (powerplant, pumping-generating plant, etc.) first; for example, YT-CU for the Yellowtail-Custer 230-kilovolt (kV) line, not CU-YT.

For the few instances of a tieline between two Regions, such as the Green Mountain-Hayden 138-kV line, or between two operating areas within a single Region, such as the Bismark-Oahe 230-kV line, the reporting offices concerned shall mutually agree which office shall furnish all information for the entire line, including **all** sections, taps, and intermediate stations. Data for each such line or intermediate stations shall appear in the report for **one operating area only**.

The type of reporting required for several conditions of line and station outages is illustrated in the sample form PO&M-62, Sheet 1 and 2, figure E-9,.

First, consider the case of a single transmission line between two terminals ALF and XV. The line is protected by a single breaker at each end and includes no intermediate switching facilities, loads, or tap points. If a breaker opens at either end or if both breakers open, the occurrence should be reported as an outage. The outage duration would be the time elapsed between opening of the first breaker and closure of the last breaker. If the duration was **1 minute or less**, insert “MØM” for momentary (see entry for day 1 at 0029 on sample form PO&M-62, Sheet 1 of 2, figure E-9). If the outage was greater than 1 minute, indicate the extent in hours and minutes, with a colon separating hours and minutes. (See entry for day 27 at 2207 on sample form PO&M-62, Sheet 2 of 2, figure E-9).

Next, consider the condition of the same line as above (ALF and XV), protected by more than a single breaker at one or both terminals. This would occur if a ring bus, breaker-and-a-half, or double-bus-double-breaker arrangement were in use at one terminal, or both. For this case, the line should be reported as experiencing an outage **only** when through power flow from one end to the other was not possible. The outage duration to be reported would be the length of time that the condition existed.

Next, consider some cases of outages on a more complicated system arrangement involving intermediate line sections, loads, tap lines, and switching facilities between terminal breakers, such as the hypothetical system arrangement show in figure E-10.

Consider first the case of a fault somewhere on the system between P and Q, and assume that in the process of clearing the fault and restoring services, **all facilities between P and Q were de-energized for exactly the same period of time**. The entries for this type of event are illustrated, for day 4 at 0850 on the sample form PO&M-62, Sheet 1 of 1, figure E-9. The entries appear for the main line P-Q, and for **each** of the intermediate substations R and T; and because the **outage duration was equal for all facilities between P and Q, separate entries are not required and should not be made for intermediate sections of the main P-Q line** (such as P-R, R-S, and S-Q, or for radial or tap lines such as S-T). In the case of a **station which contains more than one bus**, such as R, separate entries are required for each bus experiencing an outage, rather than a single entry for the complete station. Every bus and voltage must be separately identified.

Now consider the more complicated condition of an outage on the system of figure E-10, in which different outage durations occur for several of the facilities between P and Q. Such a condition might develop from the following sequence of events:

- (a) A permanent fault at the location “X” on the R-S line section, causing breakers at P and Q to open simultaneously and lock open.
- (b) After location of the fault at X, isolation of the R-S line section for repair by opening sectionalizing switches S-1075 and R-2017.
- (c) Restoration of service to station R by closing breaker P-47s.
- (d) Following (c), restoration of service to T by closing breaker Q-672.
- (e) After completion of the repair work, reenergization of line sections R-S by closing switch R-2071.
- (f) Following (e), closure of switch S-1075 to reestablish continuity of the complete line between P and Q.

The entries for the type of event identified above are entered for day 4 at 1625, on the sample form PO&M-62, Sheet 1 of 1, figure E-9. Note that entries are required for the complete line P-Q; for each of the intermediate line sections P-R, R-S, and S-Q; for the tap line S-T; for the station T; for both the 69-kV and 57-kV buses at the station R; and for the 13.8-kV bus at station T. **Note especially that when intermediate sections of a complete line experience different outage times, the outage duration for the complete line between breakers is to be indicated by a series of zeros.**

Some other outage conditions require special consideration, such as (1) a line being intentionally de-energized **for operational reasons** but being instantaneously available for reenergization and return to normal service whenever desired; and (2) entries concerning non-Reclamation facilities (lines, plants, or stations) or operation of Reclamation equipment through which connection is made to another (foreign) utility.

The condition of intentionally switching a line out of service for **operational reasons**, (identified above), should be reported as an outage for the duration applicable. This special type of operational outage is identified by the code “Ø” inserted in the “Outage” column under the subcolumn titled “Type.” Also see discussion under item 19, Type of Fault.

It is realized, however, that, in many of our power operation centers, form PO&M-62 frequently is the only consolidated chronological record of power system outages and service interruptions for a large interconnected network, **including** numerous important non-Reclamation facilities. As such, it could contain pertinent data and might be the only source from which information might be reconstructed regarding the time, duration, cause, location, and effects of system disturbances originating on either Reclamation or non-Reclamation systems. The data currently entered on

the PO&M-62 report form will eventually be entered directly into the POMTS, once that feature is enabled.

The POMTS will provide reports containing the same data that the current “Annual Summary of Transmission Line Outages” and the “Annual Summary of Substation Outages” reports provide.

There are no objections to the continued recording of outage or service interruption data on important foreign interconnecting facilities. It is essential however, that non-Reclamation ownership of such facilities be indicated in a subsequent column on the form headed “Foreign Owner” (item 15). Approved codes for numerous “foreign” utilities are listed in various sections of FIST Volume 4-2.

9. **Type** – Insert the facility code for every facility (transmission line, switchyard, or substation) experiencing an outage. Use the approved single-letter code designation in FIST Volume 4-2. For the purposed of this report, a “switchyard” is defined as the switching and transforming facility directly associated with a powerplant or a pumping-generating plant; all other switching and transforming facilities are considered “substations.” Enter the respective code (C, H, L, P, S, U, or X). Example, if the facility is a substation, insert “H”; if a pumping plant “U”; if a transmission line – “L”; etc.
10. **KV** – Insert the nominal voltage of every facility (line, substation, bus, etc.) in kV, with no more than one figure to the right of the decimal point. (See entry of 12.5 for day 4 at 0850 on sample PO&M-62 report form, Sheet 1 of 2, figure 9.)
11. **Bus, Section** – In the event operation of equipment results in a bus outage at a station that contains two or more bus sections at the same voltage, identify the particular bus section(s) involved, such as “1,” “A,” “NW” for Northwest, etc. Confine the designation to a maximum of four characters. Otherwise, leave this column blank.
12. **Bus, Dead** – Indicate by “Y” for “yes” if equipment operation at a switchyard or substation resulted in deenergization of a bus section, even momentarily. For operation of one or more switches or breakers that did not result in an outage of a bus, indicate “N” for “no.” **Every entry for an individual bus within a station should include either a “Y” or an “N” in this column. This column should be blank for all entries concerning transmission line or transmission cable outages.**
13. **Duration** – For each outage, with elapsed time of more than 1 minute, insert the total elapsed time of the outage in hours and minutes.

NOTE: If the duration is **1 minute or less**, indicated “MØM” for momentary (see entries for day 4 at 1625 and day 1 at 0029 on sample form PO&M-62, Sheet 1 of 2, figure E-9 for two examples).

Using figure E-10, if the condition occurred where all facilities between stations P and Q experienced an outage of equal time, the duration to be reported is the elapsed time that all the affected facilities were de-energized. (See entry for day 4 at 0850 on sample for PO&M-62, Sheet 1 of 2, figure E-9.)

If outages of different durations occurred for the various components of a system, sectionalized between terminal breakers, insert the actual time in hours and minutes that each facility was de-energized. For example, using figure E-10, each outage time for all intermediate components (i.e., line section, taplines, and/or substations) between stations P and Q would be recorded.

NOTE: OR **this situation only**, the outage duration for the **complete** line section (i.e., P-Q) between terminal breakers is indicated by a series of zeros.

(See the entries for day 4 at 1625 on sample PO&M-62, Sheet 1 of 2, figure E-9.)

For the condition of one or more breaker and/or relay operations discovered during routine rounds of inspection at unattended stations, “MØM” is inserted in this column (see entries for day 12 and 14 on sample PO&M-62, Sheet 2 of 2, figure E-9).

14. **Breaker Tripped** – Insert the station designation (using the station abbreviation identified in FIST Volume 4-2) and assigned breaker number of the breakers that tripped during the outage. Use a separate line for each breaker designation along with the associated relay information.
15. **Foreign Owner** – If the entry concerns a non-Reclamation facility (line, plant, or station) or operation of Reclamation equipment through which connection is made to a “foreign” utility, insert the utility designation using the code designation identified in FIST Volume 4-2. **Otherwise, leave space blank.**
16. **Relays Operated** – Information on the type of relay that operated and the targets identified is included in this section. Items 17 “Type” and 18 “Targets” provide instructions for completing those respective sections of the PO&M-62 report form.

17. **Type** – Insert the relay type, as designated by the device number on the station single-line diagram. If more than one relay operated, use an individual entry, on a separate line, for information pertaining to each relay. If the outage did not result from a relay operation but from manual operation of a breaker or switch, enter “MANUAL” in this column.
18. **Targets** – If multiple target indications are possible on a particular relay, show the relay target(s) indicated, such as “I” for Instantaneous, “T” for Time-delay, “Z” for Zone 1, “Z2” for Zone 2, “TT” for Transfer Trip, etc. If identification of specific phase(s) involved is considered desirable, add it in the “Remarks” column.
19. **Type of Fault** – For forced outages, resulting from electrical faults, insert the fault code, identified in FIST Volume 4-2 (i.e., 3PH represents a three-phase fault, L-L represents a line-to-line fault, etc.). If the fault type is unknown, uncertain, or undetermined, insert “UNK.”

For other forced outages, such as system oscillations or the intentional removal of equipment from service to prevent damage or failure, leave this column blank. This column also should be left blank for all scheduled (S) and operational (Ø) type outages.

20. **Customer Service Interrupted** – This column contains entries for each facility experiencing an outage identified in item 8 (column titled “Name or Terminals”). Insert “Y” (yes) to indicate that service to a Reclamation customer was interrupted, “N” (no) to indicate no interruption occurred, or “I” (interconnections) to indicate that service was supplied by wheeling over an interconnected foreign system, and it was not known whether any off-system Reclamation customer suffered an interruption in service as the result of the reported outage.
21. **Outage** – Information on the type of outage that occurred and the reason for the outage is included in this section. Items 22 “Type” and 23 “Reason” provide instructions for completing those respective sections of the PO&M-62 report form.
22. **Type** – Insert an “F,” “S,” or “Ø” to indicate whether the outage was forced, scheduled, or operational.

A **forced outage** results from emergency conditions requiring that essential equipment be taken out of service immediately, either automatically or as soon as switching operations can be performed, or results from improper operation of equipment or employee error.

A **scheduled outage** results when equipment is deliberately taken out of service at a selected time, usually for purposes of construction, maintenance, or repair.

NOTE: If it is possible to defer the outage, it is a scheduled outage; otherwise, it is a forced outage. Deferring an outage may be desirable, for example, to prevent overload of other facilities or an interruption of service to customers.

An **operational outage** occurs when a transmission line is intentionally switched out of service for operational reasons. The code “Ø” is **only** used to designate the condition on a line removed from service for control of system voltage; reduction of light-load line charging; or regulation of reactive-power distribution, where the line remains instantaneously available for reenergization and return to normal service whenever required.

23. ***Cause or Reason Code*** – Insert the code, using the FIST Manual 4-2, Power O&M Codes for ADP, Section 4.7.2, Cause or Reason Codes, that best identifies the cause or reason for the outage.
24. ***Remarks*** – Provide a brief description of maintenance performed and the cause or reason for each outage.

MONTHLY REPORT OF TRANSMISSION SYSTEM OUTAGES																	
PO&M-62 (Rev 2-2012) Bureau of Reclamation																	
OPERATING AREA Blackwater																	
MONTH November																	
YEAR 2012																	
SHEET 1 OF 2																	
REG 9																	
DATE YR MO 1211																	
DAY	TIME	NAME OR TERMINALS	TYPE	STATION, LINE, LINE SECTION, OR TAP		KV	BUS	DURATION (HRS:MIN)	BREAKER TRIPPED (STR-NO.) (1)	FOREIGN OWNER	RELAYS OPERATED		TYPE OF FAULT	CUS. INT. (2)	OUTAGE		REMARKS
				TYPE	TAB-GETS						TYPE (1)	CAUSE OF REASON (1)					
01	0000	PHK	H		PHK-456	230		192:15						N	S	MAI	Completed uprating of breaker started October 18.
01	0029	ALF-XV	L			230		MOM			94 167G 3	I	L-G	N	F	LIG	Lightning in Xavier area.
04	0850	P-Q	L			138		0:07			121 167G I	Z2	2LG	Y	F	WIN	High winds in Salem area.
04	1625	P-Q	L			138		00000			121 121 167G I	Z2 Z1 I	UNK	Y	F	ICE	Broken crossarm on structure 17/3 of Randolph-salem line section. Service restored to Randolph from Palmer at 1737. Service restored to Tabor from Quay at 1933. Crossarm replaced on structure 17/3 and Randolph-salem line section reenergized at 0650 November 5, by closing R-2071. S-1075 closed at 0740 November 5.
08	1414	MED	S			230	SW	3:45			187B 1		1LØ	N	F	MED	Weld joint failed on "A" phase of southwest section of 230-kV bus at Medford Powerplant Switchyard.
08	0921	GF	H			230		0:32	NAE		121	Z1		N	S	TES	Staged 3-phase fault test on GF-MIV line following change of relay settings.

(1) REFER TO FIST VOLUME 4-2 FOR APPROVED CODING. (2) CUSTOMER SERVICE INTERRUPTED.

Figure E-9. Completed PO&M-62 Report Form; Sheet 1 of 2 for Hypothetical Power System in figure E-10.

MONTHLY REPORT OF TRANSMISSION SYSTEM OUTAGES															
OPERATING AREA <u>Blackwater</u>										SHEET <u>2</u> OF <u>2</u>					
MONTH <u>November</u>										REG <u>9</u>	DATE YR MO <u>1211</u>				
YEAR <u>2012</u>															
DAY	TIME	NAME OR TERMINALS	TYPE (1)	KV	BUS		DURATION (HES:MIN)	BREAKER TRIPPED (STR-NO.) (1)	FOREIGN OWNER (1)	RELAYS OPERATED TYPE	TYPE OF FAULT (1)	CUS. SER. INT. (2)	TYPE (1)	CAUSE OR REASON (1)	REMARKS
					SEC	DEAD									
12	1550	WM	H	12.5		N	MOM	WM-124		151G	UNK	Y	F	UNK	Time of reset. Operating time unknown.
13	0017	FR-UJ UJ-SF UJ-SC	L	230			8:04 8:05 8:06					N Y Y	Ø Ø Ø		Control of light-load voltage in st. Fall and South Center areas over weekend.
14	0945	WP	H	34.5		N	MOM	WP-742	MCE	UNK	UNK	Y	F	UNK	Time of reset. Operating time unknown.
*	*	(Repeat data on line above 8 times).													
27	2207	ALF-XV	L	230			1:43	XV-892 ALF-1492		167G3 94	I	N	F	LIG	Lightning in Xavier area. XV-892 reclosed successfully. ALF-1492 failed to reclose due to trouble in closing circuit.
27	2309	CH	H	115		N	0:04	CH-762	MSP	187T		I	F	UNK	Trouble on North-South Power Co. 115-KV system.
(1) REFER TO FIRST VOLUME 4-2 FOR APPROVED CODING. (2) CUSTOMER SERVICE INTERRUPTED.															

Figure E-9. Completed PO&M-62 Report Form; Sheet 2 of 2 for Hypothetical Power System in figure E-10.

MONTHLY REPORT OF TRANSMISSION SYSTEM OUTAGES

FORM 62 (12-86)
Bureau of Meteorology

SHERBY 1 OF 2

REG. NO.	DATE	CARD
1	9-8	10-11
9	8711	14

OPERATING AREA Blackwater MONTH November YEAR 1987

DAY TIME	STATION, LINE, LINE SECTION, BUS			DURATION (HRS-MIN)	BREAKER TRIPPED (STA., NO.)	RELAYS OPERATED	FACTORY	OUTAGE	REMARKS
	NAME OF TERMINALS (1)	KV	SECT						
01 0800	PIIK	H 230		1:02:15	PIIK-456			S MAI	Completed uprating of breaker started October 18.
01 0829	AIF-XV	L 230		1:00:00	AIF-1492 XV-892	94 16763 I	L-G N	F LIG	Lightning in Xavier area.
04 0850	P-Q	L 138		0:07	P-472 Q-672	121 72 1676 I	ZIG Y	F WIN	High winds in Salem area.
04 1625	P-Q	L 138		0:07	P-472 Q-672	121 22 121 21 1676 I	UNK Y	F TCF	Broken crossarm on structure 1775 of Randolph-Salem line section. Service restored to Randolph from Palmer at 1737. Service restored to Faber from Quay at 1933. Crossarm replaced on structure 1773 and Randolph-Salem line section reenergized at 0650 November 5, by closing R-2071. S-1075 closed at 0740 November 5.
08 1414	MED	S 230	SW	3:45	MED-582 MED-782 MED-1182 MED-1782	18781	LLN N	F MEC	Welded joint failed on "A" phase of southwest section of 230-kV bus at Medford Powerplant Switchyard.
08 0921	GF	H 230		0:32	GF-582	121 21	N	S TES	Staged 3-phase fault test on GF-MIV line following change of relay settings.

(1) REFER TO FIST VOLUME 4-2 FOR APPROVED CODING. (2) CUSTOMER SERVICE INTERRUPTED.
REFER TO FIST VOLUME 1-3 FOR DETAILED INSTRUCTIONS ON REPORTING.

Figure E-9. Continued.

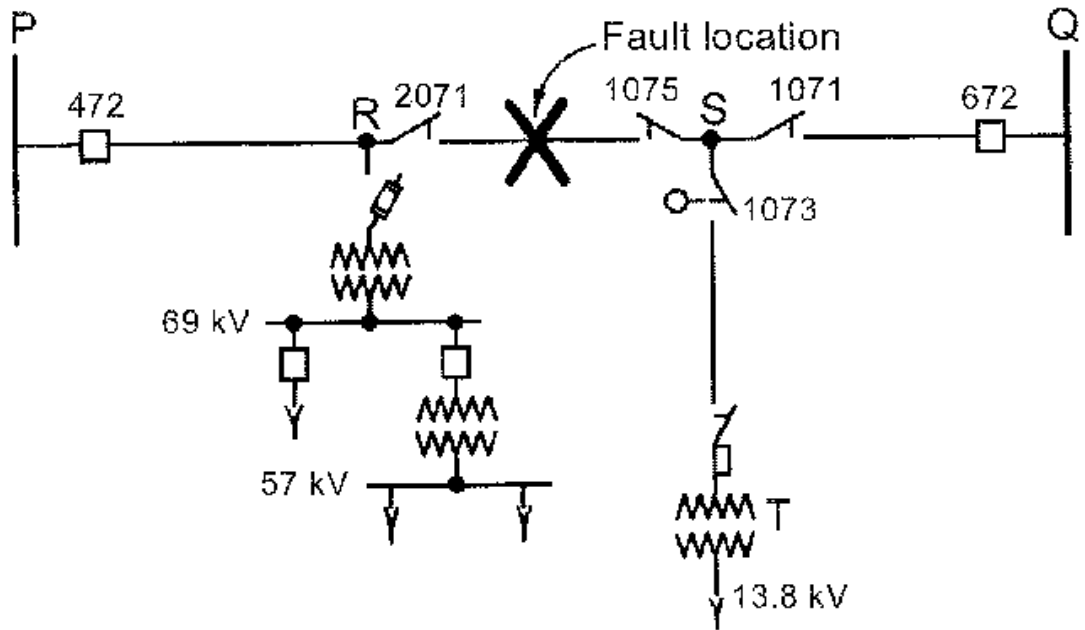

Figure E-10. Diagram of Hypothetical Power System.

**Bureau of Reclamation – POMTS Reports
PO&M-59 Report – Power Plants (Final Version)**

Date: 4/19/2012

Project: Colorado-Big Thompson **Plant:** Pole Hill **Reporting Month:** 01/2012 **Last Modified Date:** 2/7/2012 02:33PM
NERC Compliant Reporting Facility: Y **Plant Factor:** 24.14% **Utilization Factor:** 39.23% **Installed Capacity (kW):** 38,238

Gross Gen (kwh)	6,869,000	Plant Aux (kwh)	64,000	Net Gen (kwh)	6,804,100	Max Hr Gen (kwh)	15,000	Condenser Operation (kwh)	0	Water for Gen (AF)	11,179
Other Water Releases (AF)	8,539	Water Factor	56.69%	Calc Kwh Gen/AF	614.46	Forebay (ft)	7,418.02	Tailrace (ft)	6,579.51	Total Flow (cfs)	0.00

Unit 1													
Unit Capacity (kW)	38,238	Gross Gen (kwh)	6,689,000	Unit Starts	6	Hours in Month	744	Time Operated (Hours:Min)	500:43	Time Avail (Hours:Min)	500:43	Outage Duration (Hours:Min)	243:17

AVR/PSS Reporting

MVA Rating	AVR	AVR Status Hours/Off	0.00000	AVR In Service %	100.00%	AVR Comment
40.30	Y					
	PSS	PSS Status Hours/Off	0.00000	PSS In Service %	100.00%	PSS Comment
	Y					

Outage Outage Type Date

Outage Type	Outage Date	Outage Time	Outage Duration	Event Code	Maintenance Desc
S	01/18/2012	10:20	3:34	7120	Unbalanced Headgate Testing/Changed Pulsed Response on Timer for Speed Changer
F	01/16/2012	09:41	6:54	7142	Broken Shear Pin
SC	01/01/2012	00:00	232:49	9199	Annual Maintenance/Install Relays/RTU Commissioning *Ran While Unavailable 3:00

Figure E-11. POMTS Generated PO&M-59 Report with AVR/PSS Information Included.

Appendix E-6 – Instructions for Completing Automatic Voltage Regulator and Power System Stabilizer Reports

Figure E-12 is a sample of a completed AVR-PSS Report. Instructions for reporting under the various headings, in the sequence in which they appear on the form is as follows:

1. **Region** - Enter the designated name of the reporting Region.
2. **Month and Year** – Insert the name of the Month and the current Year for the reporting period.
1. **Powerplant** – Insert the official name of the specific facility (powerplant or pumping-generating plant [P-G] for the reporting period).
2. **Unit** – Insert the generator number.
3. **Unit Capacity (kilowatts [kW])** – Insert the nameplate capacity of the generator in kW.
4. **Plant Capacity** – Insert the total nameplate capacity of the plant in kW.
5. **AVR** – Identify yes or no (insert “Y” or “N”) if the unit is equipped with an automatic voltage regulator.
6. **PSS** – Identify yes or no (insert “Y” or “N”) if the unit is equipped with a power system stabilizer.
7. **Total TimeUnit Operated** – Insert the total number of hours (rounded to the closest tenth of an hour) that the unit operated connected to the system (online).
8. **Total Time AVR Off** – Insert the total number of hours (rounded to the closest tenth of an hour) the unit operated connected to the system and the AVR was not operating in voltage control mode (AVR off).
9. **Percent (%) of Time AVR In Service** – Calculated as the total number of hours the unit operated with the AVR in service to the Total Time Unit Operated (item 9) expressed in percent (let say a unit operated [online] for 742 hours and 12 minutes or 742.2 hours, and the AVR was out of service for 30 minutes (.5 hrs) during that time. Subtracting the time the AVR was out of service (30 minutes) from the total time the unit operated (742:12) indicates the unit operated (online) for 741:42 (or 741.7 hours) with the AVR in service. $741.7 \div 742.2 = 99.93\%$. The AVR was in service 99.93% of the time the unit was

operated (see the entries for Green Tree Unit 1 on sample AVR/PSS Report, figure E-12.)

10. **Total Time PSS Off** – Insert the total number of hours (rounded to the closest tenth of an hour) the unit operated connected to the system and the PSS was not operating in voltage control mode (PSS off).
11. **Percent (%) of Time PSS In Service** – Calculated as the total number of hours the unit operated with the PSS in service to the Total Time Unit Operated (item 9) expressed in percent (example: the unit operated [online] for 512 hours and 38 minutes or 512.6 hours, and the PSS was out of service for 18 minutes (.3 hrs) during that time. Subtracting the time the PSS was out of service (18 minutes) from the total time the unit operated (512:38) indicates the unit operated (online) for 512:20 (or 512.3 hours) with the PSS in service. $512.3 \div 512.6 = 99.94\%$. The PSS was in service 99.94% of the time the unit was operated (see the entries for Black Owl Unit 1 on sample AVR/PSS Report, figure E-12.)
12. **Comments** – Insert any pertinent comments (i.e., reason the AVR or PSS was out of service). See explanation for Green Tree Unit 1 and Black Own Unit 1 in the comment section, figure E-12.

Appendix F – Facility Abnormal Operations

The following information is generic in scope and is provided as example events and/or conditions to consider when creating site-specific response procedures for abnormal and/or emergency operations.

A. Flooding in the Facility

NOTE: A failure of a penstock, scroll case door/gasket, draft tube door/gasket, or head cover would cause catastrophic damage to the facility.

- (1) If a failure of a penstock, scroll case door/gasket, draft tube door/gasket, or head cover has occurred:
 - (a) Sound the plant evacuation alarm.
 - (b) If the failed penstock or head gate is identified, close the specific unit penstock gate in accordance with (IAW) local facility instructions.
 - (c) If it is not known which one failed, close all penstock gates to protect the facility IAW local facility instructions.
 - (d) If a failure of the sump pumps occurs, usage of (site-specific eductor or temporary sump pump) is required.

B. Loss of Station Service

- (1) The loss of Station Service can cause many significant problems in a facility including:
 - (a) Loss of generator auxiliaries, including cooling water, lube oil pumps, and governor oil pumps.
 - (b) Flooding from loss of sump pumps.
 - (c) Loss of power to emergency equipment (site-specific, fire pumps, alarms, etc.).
 - (d) Loss of the ability to bypass water.
 - (e) Loss of station air systems.
 - (f) Loss of transformer cooling.

- (g) Loss of battery chargers (site-specific plant battery, Supervisory Control and Data Acquisition (SCADA) battery, Uninterruptible Power Supply [UPS] battery).
- (h) Loss of power to restore penstock intake gates.
- (i) Loss of Oil Pressure Systems.
- (j) Exit issues including elevator failures.
- (k) Loss of facility services including water, wastewater, lighting, and heating, ventilation, and air conditioning (HVAC).

NOTE: A loss of station service may cause a loss of Main Unit Auxiliaries. This could cause overheating of the generator windings and lube oil system and may cause bearing damage. If you have designated Main Units to provide station service, you may want to continue to operate them to allow the re-energization of station service.

- (2) For blackstart plants, initiate blackstart procedures.
- (3) Stop any unit unwatering operations to conserve sump capacity.
- (4) For a complete failure of station service from a major fault or fire, perform the following:
 - (a) Shut down Main Units to prevent damage caused by a loss of auxiliaries.
 - (b) Close the intake gates.
 - (c) Drain the unit penstocks by cracking open the unit wicket gates. This will prevent unit creep once station service air pressure is lost and will limit inflow to plant sumps.
 - (d) Leave wicket gates slightly open to drain off intake gate leakage.
 - (e) Manually block the unit brakes.
- (5) If the units trip, verify that the units shut down completely.

CAUTION: A loss of power may prevent the operation of plant eductors if they are operated or water is supplied from the penstock. Facility should consider alternative means to remove water on a loss of power.

- (6) If you have manually operated eductors (site-specific), operate them to control sump levels.
- (7) Ensure (site-specific) that emergency generators have started. Ensure that critical loads are being fed, and monitor generator for proper operation.
- (8) If a Main Unit is left on to assist with restoring station service:
 - (a) Operate the unit at minimum load, but not condensing.
 - (b) Take unit off automatic generation control (AGC).
 - (c) Minimize load changes to conserve governor pressure.
 - (d) Monitor battery and reduce direct current (dc) loads to conserve energy.
 - (e) Monitor bearing metal/oil and generator air temperatures. Reduce load or shut down the unit, as necessary, to reduce temperature rise.
 - (f) Monitor transformer temperatures and reduce loading as necessary to minimize temperature rise.
- (9) Verify that personnel are not stuck in elevators.
- (10) Implement facility procedures to maintain downstream flows.
- (11) Conserve station air system by securing maintenance operations that consume air.

C. Loss of Plant dc Control and Protection

- (1) A loss of the dc system will cause a loss of control and protection circuits.
- (2) Check that the units have tripped and are shutting down.

CAUTION (Site-Specific): Manually opening a large switchgear breaker may be hazardous. Facilities should develop site-specific procedures to respond to a generator breaker trip failure.

- (3) Ensure that generator breakers are open. Manually trip breakers that have not opened.

- (4) Ensure that transformer breakers are open. Manually trip breakers that have not opened.
- (5) Secure the Main Units as follows:
 - (a) Close the intake gates.
 - (b) Drain the unit penstocks by cracking open the unit wicket gates.
 - (c) Leave wicket gates slightly open to drain off intake gate leakage.
 - (d) Manually block the unit brakes.
- (6) Investigate loss of dc system.

D. Loss of Plant Control Alternating Current (ac)/Uninterruptible Power Supply

- (1) The loss of the Plant Control ac system may cause the loss of the following (site-specific) systems:
 - (a) SCADA
 - (b) Instrumentation/metering
 - (c) Digital governors
 - (d) Fire alarms/detection
 - (e) Power system stabilizer (PSS)
- (2) If all control room indication of units is lost (metering and SCADA), dispatch personnel to locally monitor and/or operate units (site-specific or Continuity of Operations [COO] Plan).
- (3) If units are SCADA operated and UPS power to SCADA is lost, initiate procedures to take manual operation of units.
- (4) If the generation is not essential, consider shutting the units down.
- (5) If generators must remain operational, minimize load changes.
- (6) Investigate loss of ac plant control.

E. Loss of Air Systems

NOTE: Some facilities have separate systems for governors, breakers, and station air.

- (1) If a major failure occurs in the station air system piping:
 - (a) Secure station air compressors.
 - (b) Secure condensing operations.
 - (c) Shut down units beginning to creep and ensure penstock gate closure and thrust pump starting.
 - (d) Isolate the air leak and restore the air system.
- (2) If air compressors have failed:
 - (a) Implement air system cross-connect procedures or emergency air supply (site-specific).
 - (b) Investigate the failure of the air compressors and restore system.
 - (c) Take manual control of all air operated cooling water control valves until station air system is restored.
- (3) If a loss of unit governor air occurs, minimize load changes to conserve governor pressure. The main units will trip, and the intake gate will close at a low governor pressure (site-specific).
- (4) If a major failure occurs in the governor air system piping:
 - (a) Secure governor air compressor(s).
 - (b) Isolate piping failure and restore system.
- (5) If governor air compressor(s) have failed, perform the following:
 - (a) Implement governor air system cross-connect procedures or emergency air supply (site-specific).
 - (b) Investigate the failure of air compressor(s) and restore system.

NOTE: A loss of generator breaker operating air may cause the breaker to lock out, open, or close breaker (site-specific).

- (6) If Unit Breaker's operating air is lost, minimize breaker operations to conserve operating air.
- (7) If a major failure occurs in Unit Breaker air system piping:
 - (a) Secure breaker air compressor(s).
 - (b) Isolate piping failure and restore system.
- (8) If Unit Breaker air compressor(s) have failed, perform the following:
 - (a) Implement governor air system cross-connect procedures or emergency air supply procedure (site-specific).
 - (b) Investigate the failure of breaker air compressor(s) and restore system.

F. Generator and Transformer Breaker Abnormal Operations

- (1) A breaker failure relay (BFR) will indicate a failed breaker to the Operator (site-specific).
- (2) The BFR should operate appropriate breakers to isolate the failed breaker.
- (3) If the breaker fails to open or to be isolated, open the switchyard breaker or manually open the breaker (site-specific).

CAUTION: Do not open breakers manually with low sulfur hexafluoride (SF₆), air, or oil pressures. This could cause catastrophic breaker failure and personal injury.

CAUTION (Site-Specific): Manually opening a large switchgear breaker may be hazardous. Facilities should develop site-specific procedures to respond to a generator breaker trip failure.

NOTE: Breakers should have a breaker failure scheme.

- (4) If breaker fails to operate:
 - (a) Check whether the red and green lights on breakers are operational. This verifies continuity through the closing and tripping circuits.

- (b) Check oil/air/SF₆ pressure.
- (c) Check synchronizing circuit, local/remote switch (site-specific).
- (d) Check that control power is available.
- (5) If a loss of SF₆ occurs, refer to FIST 5-9, Safe Handling Procedures for SF₆ Equipment.
- (6) Low breaker operating pressure will prevent the operation of air blast breakers. The low-pressure alarm operates at (site-specific).
- (7) For low breaker air pressure, the Operator will do the following:
 - (a) Attempt to locate and isolate the leak.
 - (b) Check the breaker air compressor status, including the power supply and fuses.
 - (c) Implement air system cross-connect procedures or emergency air supply (site-specific).

G. Plant Running Isolated (Not Connected to Grid)

- (1) In this condition, the facility is a step closer to a blackout condition.
- (2) Immediately maintain station service voltage and frequency. Failure to do so can cause electrical equipment failures.
- (3) Plant staff should minimize the use of non-essential electrical equipment (compressors, cranes, pumps, etc.).
- (4) Initiate recovery procedures with Power Marketing Agency (site-specific).

H. Carbon Dioxide (CO₂) Discharge

CAUTION: Do not enter lower areas of the facility where CO₂ could collect. Time should be allowed for CO₂ to dissipate. Areas must not be entered without a self-contained breathing apparatus (SCBA) and air monitor.

NOTE: Reset the initiating devices or relays prior to resetting the CO₂ system (site-specific).

- (1) Verify operating unit shutdown.
- (2) If the plant is manned, operating personnel should monitor the generator for signs of a fire. If fire is present, additional CO₂ should be discharged.
- (3) Plant personnel should be warned of the danger of concentrations of CO₂ in low places and should evacuate lower elevations of the facility for at least 30 minutes.
- (4) Entries into these areas must be IAW established Job Hazard Analysis (JHA). Anyone entering these areas should carry a SCBA and an air monitor.
- (5) Evacuate the facility or lower areas of the plant (site-specific).

I. Differential or Ground Relay Operation

- (1) When a unit is shut down by operation of the differential or ground relays, the Operator should take the following action:

CAUTION: DO NOT restart the unit until the problem has been identified and corrected. Failure to identify and correct the problem could cause permanent damage to the windings and core.

- (a) Always ensure that the unit has come to a complete stop.
- (b) Ensure that CO₂ has discharged (site-specific details) and determine if additional discharges are required.
- (c) Refer to section on CO₂ discharges.
- (d) Notify the Facility Manager or Operations Head.
- (e) The unit should not be restarted until the cause of the shutdown has been investigated and repaired, if necessary.

J. Overcurrent Relay Operation

- (1) Overcurrent relays are not likely to operate on overload, unless the overload is accompanied by a very high reactive load.
- (2) The relay protects the generator against sustained excessive currents and against external faults that do not clear, such as switchyard bus faults or line faults.

- (3) If a unit overcurrent relay operates, ensure that unit 86-lockout and unit shutdown occurs.
- (4) When a single unit trips on overcurrent, the Operator should check for trouble in the excitation system.
- (5) When several units trip simultaneously on overcurrent, the Operator should check for the possibility of a switchyard bus fault or a line fault that failed to clear.
- (6) The unit may go back online as soon as the problem is corrected.

K. Overvoltage Relay Operation

- (1) The generator overvoltage relay provides protection against dangerously high generator voltages.
- (2) If a unit overvoltage relay operates, ensure that unit 86-lockout and unit shutdown occurs.
- (3) If the unit was tied to the grid and supplying a significant voltage support, a grid disturbance could have caused the relay actuation.
- (4) The excitation system should be inspected to determine the problem.

L. Loss of Generator Field

- (1) When loss of the generator field occurs with the unit connected to the system, leading reactive flows into the machine to help maintain the generator terminal voltage.
- (2) If a unit loss of field relay operates, ensure unit 86-lockout and unit shutdown occurs.
- (3) The following should be inspected to determine the loss of field.
 - (a) Excitation system
 - (b) Field breaker
 - (c) Collector ring
 - (d) Brush assembly
 - (e) Associated bus work

M. Abnormal Operation of the Voltage Regulator

CAUTION: Voltage regulators should not be operated in manual or current mode without an Operator present or for extended periods of time. Western Electricity Coordinating Council (WECC) or the Local Control Area must be notified of all units that are being operated with the voltage regulator in manual.

- (1) When abnormal conditions occur in the voltage regulator or the excitation system, the voltage regulator should be taken out of service by shutting the unit down.
- (2) The voltage regulator may automatically swap to the manual mode on a failure of the automatic voltage regulator.
- (3) The voltage regulator and excitation system should be inspected and the problem corrected before restarting the unit.

N. Stator Winding High Temperature

- (1) The stator winding temperature high limit is monitored by embedded temperature detectors and are set at (site-specific) degrees Celsius.
- (2) Remotely operated units at facilities that are currently unmanned should be unloaded first to reduce temperatures to a safe operating limit. If load reduction does not reduce high temperatures, shut down the unit.
- (3) While high stator temperatures should not occur except at rated load and above, Operators should watch for higher than normal temperatures at lower loads.
- (4) When abnormal temperatures occur, Operators should check for:
 - (a) Proper generator air-cooling water flow (site-specific)
 - (b) Hot spots
 - (c) Air-locked coolers
 - (d) High field current or temperature
- (5) If the temperature exceeds the maximum of (site-specific) degrees Celsius, the load and/or reactive should be reduced to bring the temperature back to the limit. Raising the generator voltage slightly to reduce armature current may be helpful, especially if the reactive is on the leading side.

- (6) If the cause of the high temperature is not found and corrected, the unit should be unloaded and shut down until the condition can be corrected.

O. Main Field Winding High Temperature (If Applicable)

- (1) The main field winding temperature may be calculated from rotor current (facility specific).
- (2) Remotely operated units whose facility is also currently unmanned should have the field current reduced to bring temperatures to a safe operating limit. If lowering the field current does not reduce high temperatures, shut down the unit.
- (3) When the indicated field temperature reaches (site-specific) degrees Celsius, the Operator should take the following action:
 - (a) Check the stator temperature and the field current.
 - (b) If the stator temperature is below its limit of (site-specific) degrees Celsius and the field current is below its limit (site-specific), it is unlikely that the field temperature is too high.
 - (c) If the field current is above the limit or if the stator temperature is too high, reduce the generator reactive and megawatt load.
 - (d) High temperature may be an indication of an increase in the resistance of the winding as a result of the development of high resistance joints in the connections between coils. If this is suspected, the Facility Manager or Operations Head should be notified.

P. Generator Bearing Temperature Alarm or Shutdown Relay Operation

- (1) The generator-bearing high temperature alarm actuates at (facility specific) and will cause a unit shutdown at (facility specific).
- (2) If the unit receives a trip actuation, verify that the unit is shutting down normally. If it isn't, initiate a normal unit shutdown.

CAUTION: Do not use emergency shutdown (SCADA or control switch). This will open the generator breaker before the gates are closed, causing an increase in speed, which might do further damage to the bearing.

- (3) Remotely operated units at facilities that are currently unmanned should be immediately shutdown.
- (4) An immediate inspection should be made, including a check on bearing temperatures, oil flows and levels, and cooling water flow. The Operator also should check for any unusual noises or vibration of the unit.
- (5) If the bearing temperature shows a fast temperature rise of (site-specific) degrees Celsius or more above normal with other temperatures near normal, the unit should be shut down immediately.
- (6) If the temperature recorder shows a rather slow temperature rise, check to make sure that cooling water flow and oil level is normal and reduce unit load.
- (7) If temperatures continue to rise, the unit should be shut down using normal procedures.
- (8) For a slow rise in temperature, the Operator should be alert for indicator failures. When the bearing temperatures actually rise, the change is likely to show up on several indicators, rather than on only one.
- (9) SCADA or other temperature indicators may be used to validate the high temperature.
- (10) If a high temperature relay operates, ensure the unit 86-lockout and a unit shutdown occurs.
- (11) If the cause of the high temperature is not found and corrected, the unit should be unloaded and shut down until the condition can be corrected.

Q. High or Low Thrust Bearing Oil Level Alarm

- (1) The generator high oil level alarm actuates at (facility specific) and the low level alarm actuates at (facility specific).
- (2) If the unit receives a trip actuation, verify that the unit is shutting down normally. If it is not, initiate a normal unit shutdown.
- (3) Remotely operated units at facilities that are currently unmanned should be immediately shut down.
- (4) If the oil level is high:

- (a) Check for an oil cooler leak.
- (b) Check the sight glass for milky appearance and take an oil sample from the bottom of the bearing sump.
- (5) If there is considerable water in the oil, the unit should be unloaded and shut down using normal procedures.
- (6) If the oil level is low:
 - (a) The thrust-bearing temperatures should be monitored.
 - (b) Check for leaks.
 - (c) If a large leak is discovered, unload the unit and shut it down until the condition can be corrected.
 - (d) If there is no indication of a leak, oil should be added.
- (7) In cases of abnormal oil levels, all supply and drain valves should be checked to be sure they are not leaking.
- (8) If the cause of the high/low oil level is not found and corrected, the unit should be unloaded and shut down until the condition can be corrected.

R. Generator Air Cooling Water Alarm

- (1) The air-cooling water alarm is energized by:
 - (a) Low cooling water flow (site-specific)
 - (b) Low pressure (site-specific)
 - (c) High discharge air thermometers (site-specific)
- (2) When the alarm is energized, the Operator should check cooling water flow and discharge air temperatures.
- (3) If the cooling water flow is below normal, check that all supply and discharge valves are open.
- (4) Check that water supply pressure is greater than (site-specific). If supply pressure is low, check pumps and strainers.
- (5) A single high discharge air temperature greater than (site-specific) is an indication of an air-locked cooler or a closed isolation valve.

- (6) If the stator temperature gets too high, it may be necessary to reduce load to keep the temperature within limits.
- (7) If the cause of the high temperature is not found and corrected, the unit should be unloaded and shut down until the condition can be corrected.

S. Thrust Bearing Cooling Water Alarm

- (1) Thrust-bearing cooling water alarm actuates at (site-specific).
- (2) Remotely operated units at facilities that are currently unmanned should be immediately shut down.
- (3) An immediate inspection should be made to check cooling water flow greater than (site-specific). The Operator should also check for any unusual noises or vibration of the unit.
- (4) Ensure that all supply and discharge valves are open and header pressure is greater than (site-specific).
- (5) If cooling water flow cannot be restored, the unit should be shut down.

T. Thrust Bearing Temperature Alarm or Shutdown Relay Operation

- (1) The turbine-bearing temperature alarm will be energized by any of the following:
 - (a) Bearing temperature recorder (site-specific).
 - (b) Bearing metal temperature indicating thermometer (site-specific).
 - (c) Bearing oil temperature indicating thermometer (site-specific).
- (2) If the unit receives a trip actuation, verify that the unit is shutting down normally. If it is not, initiate a normal unit shutdown.
- (3) Remotely operated units at facilities that are currently unmanned should be immediately shut down.
- (4) When the alarm is energized, the Operator should check bearing temperatures.
- (5) If any temperatures are found to be above normal, inspect the bearing cooling water and the oil supply system to determine the cause of the high temperature.

- (6) The turbine-bearing can be operated temporarily without cooling water if the bearing temperature does not exceed (site-specific).
- (7) If the cooling water supply is normal, the Operator should check the shaft runout. The Operator also should check for any unusual noise or a vibration that might increase the bearing friction.
- (8) If the cause of the high temperature is not found and corrected, the unit should be unloaded and shut down until the condition can be corrected.

U. Loss of Water Supply to Packing Gland

- (1) The shaft packing requires a small amount of cooling water to help lubricate the packing and to prevent heating and seizing of the packing. The low flow alarm actuates at (site-specific).
- (2) Remotely operated units at facilities that are currently unmanned should be immediately shut down.
- (3) The Operator should check the flow of gland water on each inspection.
- (4) If the cooling water fails and the packing gets hot, the Operator should first try to restore the cooling water flow. If this cannot be done, the unit should be unloaded and shut down to prevent possible damage to the shaft sleeve.

V. Loss of Turbine Seal Lubricating Water

- (1) Some generators use seal water only during motoring/condensing. If the seal water fails and cannot be restored on a motoring/condensing unit, the unit could be operated until the problem is corrected.
- (2) The seal-water pressure and flow should be checked between (site-specific) on each unit inspection.
- (3) The low seal pressure alarm actuates at (site-specific).
- (4) Remotely operated units at facilities that are currently unmanned should be immediately shut down.
- (5) If the seal water fails on a generating unit that requires constant seal water and cannot be restored, the unit should be shut down until the problem can be corrected.

W. Failure of Turbine/Generator Bearing Oil Pumps

NOTE: The dc oil pump is a backup to the ac oil pump. The dc pump provides a continuous supply of oil to the turbine/generator bearings in case the ac pump or station service fails. In some cases, it may be acceptable to operate the unit with the dc oil pump for short periods of time. However, the unit will not have a backup oil supply. Consideration should be given (especially at remote facilities) to shutting down the unit and starting an alternate unit.

- (1) The dc pump starts on a low pressure of (site-specific).
- (2) If the unit receives a trip actuation, verify that the unit is shutting down normally. If it is not, initiate a normal unit shutdown.
- (3) Remotely operated units at facilities that are currently unmanned should be immediately shut down.
- (4) When any abnormal condition occurs in the turbine/generator-bearing oil system, the Operator should first determine if the bearing is receiving adequate lubrication. If it is not, the unit should be unloaded and shut down immediately.
- (5) When the bearing oil alarm is energized, the Operator should:
 - (a) Check that the bearing oil supply pressure is greater than (site-specific).
 - (b) Check that turbine/generator-bearing temperatures are less than (site-specific).
 - (c) Check the ac oil pump status. If the pump is not operating, check the ac pump supply breaker.
 - (d) Verify operation of the dc pump (site-specific).
 - (e) Check for oil leaks in the system that may be causing a low pressure.
- (6) If the cause of the ac pump failure is not found and corrected and the dc oil pump is not supplying proper pressure and flow, the unit should be unloaded and shut down until the condition can be corrected.

- (7) For a failure of the thrust bearing oil pump:
 - (a) Ensure that the brakes come on and the unit is shut down quickly.
 - (b) At slow speeds, the thrust bearing may not have an adequate oil film.
 - (c) Do not restart the unit until the thrust bearing pump is repaired.

X. Loss of Permanent Magnet Generator (PMG)/Speed Signal Generator (SSG)

- (1) When a loss of a PMG occurs, the unit will go to gate limit setting, and you will have no speed indication on the unit.
- (2) If the SSG fails and a generator field is not present, the speed signal will be lost, and a main unit lockout and shutdown will occur. The SSG is a backup to the generator potential transformer (PT) speed signal.
- (3) SSG and/or PT feeds speed information to electronic governors to operate speed switches (brake application, thrust pump application, etc.) and speed indicating meters.
- (4) If local plant Operators are available, some of the following actions need to be taken based on the governor type (site-specific):
 - (a) Take the brakes off automatic (auto) to prevent brake damage.
 - (b) Lower the gate limit to unload the generator and achieve the no-load speed condition.
 - (c) Manually, start thrust bearing oil pump.
 - (d) When the generator load is at minimum, open the generator breaker and shut down the unit.

CAUTION: Do not shut down the unit without placing brakes in manual. Failure to do so will damage brakes.

- (5) If the governor is a digital governor, the unit will lock out. Depending on how the governor failed, the brakes may actuate, and the thrust bearing pump may not start.

- (6) For electronic or mechanical governors, lower the gate limit to unload the generator.
- (7) When generator reaches (site-specific) revolutions per minute (rpm), manually apply the brakes.

Y. Abnormal Operation of Governor

NOTE: Hunting or surging could be an indication of a serious problem in the governor.

- (1) The most common abnormal conditions affecting governors are lack of sensitivity and hunting or surging. The Operator usually will not be able to correct either of these conditions.
- (2) For governor control problems, the unit should be taken off AGC. If this fails to correct the problem, the governor should be block loaded and the unit shut down as soon as possible.
- (3) If the speed-adjusting motor fails to operate from the control room, the Operator may be able to control the unit from SCADA using the gate limit. Additionally, the speed adjustment may be operated temporarily at the governor, but load changes should be kept to a minimum.
- (4) A loss of control power to the governor most likely will cause a unit shutdown or, at least, wicket gate closure.
- (5) Operation of a unit governor in the “auxiliary” valve mode normally is done during maintenance. When the auxiliary valve is being used during an emergency, there are several things to remember:
 - (a) The unit transfer switch may have to be turned to “manual” to prevent the automatic operation of the gate limit motor.
 - (b) Turbine speed is under the complete control of the gate limit control knob.
 - (c) There is no speed sensing by the governor, and the servomotor timing will be slower.
 - (d) The governor should never be left unattended. The automatic shutdown devices are inoperative and will not shut down the generator in an emergency.

Z. Loss of the Restoring Cable (Mechanical Governor)

- (1) If the restoring cable breaks between the gate servomotor and the sheaves, perform the following:
 - (a) If the generator is online, the indications of a broken restoring cable should be like this:
 - (i) The gate position indicator is at full open.
 - (ii) The unit will be motoring when the gate position indicates it should be producing power.
 - (b) Open the Unit Breaker under a small motoring load and take the unit offline to repair.
 - (c) If the generator is offline or operating isolated, the gate position indicator again will show full open, but the gates will close and shut down the unit.

- (2) If the restoring cable breaks between the sheaves and the restoring cable weight, what do you look for and what should you do?
 - (a) Regardless of whether the wicket gates are going open or closed during a load change, the generator will operate at maximum load with the gates full open, but the gate position indicator stays at the previous load setting.
 - (b) The Operator should use the gate limit control knob to shut down the generator.

CAUTION: Under no circumstances should the unit be tripped if it is online. Tripping a unit with no restoring cable and the wicket gates full open would result in a runaway generator.

- (2) If the pilot valve sticks in the open position and the gate limit control will not push down the pilot valve, what can you do to stop the unit?
 - (a) The Operator should cut off oil pressure to the pilot valve, only allowing the valve servomotor plunger to fall of its own weight. This will open oil flow to the closing side of the servomotor and close the wicket gates.

CAUTION: Under no circumstances should the unit be tripped if it is online. Tripping a unit with the pilot valve stuck in the open position would result in a runaway generator.

AA. Loss of Gate Position Indication (Digital Governor)

- (1) A failure of the gate positioning indicating device will cause a governor shutdown.
- (2) The unit will receive a lockout.
- (3) Verify that the unit is shutting down and the unit breaker is open.

BB. Low Governor Oil Pressure Alarm and Shutdown Relay Operation

- (1) If the low oil pressure alarm is energized, the control room Operator should stop any load changes on the unit. If the governor is hunting, block the gates with the gate limit.
- (2) If the unit receives a trip actuation, verify that the unit is shutting down normally. If it is not, initiate a normal unit shutdown.
- (3) If the alarm does not clear and the plant is unmanned, the Operator should shut down the unit.
- (4) If personnel are available, check that the governor oil pumps are running with proper discharge pressure (site-specific information), check the oil level in the pressure tank (site-specific information), and check that the governor sump level is normal (site-specific information).
- (5) Check the starting and stopping pressures of both pumps (site-specific).
- (6) If there is trouble with the lead pump, the lag pump should be put on lead. If there is complete failure of both pumps, the unit will have to be shut down.
- (7) If the low oil pressure shutdown relay operates, the unit will be automatically shut down and must be left down until the cause of the low oil pressure is found and corrected. This may cause penstock gate closure.

CC. Overspeed or Runaway

- (1) There are two types of actuations for overspeed: instantaneous and sustained. The overspeed alarm and shutdown relay are set to operate at (site-specific speed and time).

- (2) If the unit receives a trip actuation, verify that the unit is shutting down normally. If it is not, initiate a normal unit shutdown.
- (3) The Operator should monitor the unit rpm to ensure that the governor is taking control of the unit or that the unit is shutting down.
- (4) If an overspeed shutdown occurs, the entire governor system should be inspected before restarting the unit.
- (5) If the governor is acting abnormally, DO NOT open the generator breaker until the generator load is zeroed, using the gate limit.
- (6) In case of a runaway condition where the wicket gates fail to close, the Operator should close the penstock gate.

DD. Turbine Pit High Water

- (1) A turbine pit high water alarm actuates at (site-specific). A turbine pit high water pit alarm could be caused by the following:
 - (a) Head cover seal failure
 - (b) Cooling water line failure
 - (c) Turbine packing failure
 - (d) Plugged drain lines
 - (e) Head cover pump failure
 - (f) Wicket gate seal failure
- (2) Remotely operated units, whose facility also currently is unmanned, should be immediately shut down.
- (3) The high level alarm should be investigated to determine the cause of the high water alarm.
- (4) The unit operation may continue if the leak can be isolated or if the leak is small and can be repaired during a scheduled outage.
- (5) For large leaks, the unit should be unloaded, shut down, and the penstock gate closed until the condition can be corrected. If the leak is below the tail race water elevation, the tail race stop logs may have to be installed also.

EE. Failure of Gate Shear Pin

- (1) For a load rejection with shear pin failure, close the penstock gate.
- (2) The wicket gate operating linkage for each gate is provided with a safety shear pin to prevent damage to gates in case they are blocked by foreign material getting between them.

While shear pins usually fail when the gates are closed with foreign material between them, they also occasionally fail when the unit is on load.

- (3) When a shear pin fails, the Operator may notice unusual noise and vibration of the turbine or elevated turbine bearing temperatures, especially while the gate is closing.
- (4) Operators should be alert for this and should check for broken shear pins when the turbine is unusually noisy. If a broken shear pin is found, the unit should be unloaded, if possible, and operated at minimum load until the broken shear pin can be replaced.

FF. Unusual Mechanical Noise or Vibration

- (1) The Operator should investigate any unusual mechanical noise or vibration. Check shaft runout and generator/turbine bearing temperatures. Make an inspection for broken shear pins or for foreign material lodged in the gates or wheel.
- (2) If the abnormal condition is such that continued operation of the unit might do further damage or if there is evidence of foreign material in the gates or wheel, shut down the unit immediately.
- (3) If severe vibration and noise develops, shut down the unit immediately.

GG. Transformer Differential Relay Operation

- (1) When the transformer differential relay operates, the Operator should take the following action:
 - (a) Ensure that the associated generator and switchyard breakers are open.

CAUTION: Care should be taken not to de-energize transformer oil pumps of operating transformers.

- (2) Stop the transformer oil pumps (site-specific).

- (3) If fire is present at the transformer, ensure that the transformer deluge system is activated.
- (4) If no fire is present, ensure that the transformer deluge system is not operating.
- (5) If a fire has occurred, initiate the Prefire Plan.
- (6) Ensure that the associated generators are shut down.
- (7) Do not restart units until the cause of the relay action has been investigated and corrected.

HH. Transformer High Temperature Alarm of Shutdown Relay Operation

- (1) Transformers usually have cooling oil circulating pumps with fans and/or heat exchangers for removing heat. The high temperature alarm actuates at (site-specific).
- (2) If the alarm does not clear and the plant is unmanned, the Operator should unload the transformer.
- (3) The Operator should perform the following:
 - (a) Ensure transformer loading is within the limits (site-specific).
 - (b) Ensure both oil pumps are operating.
 - (c) Check that the transformer oil level is normal (site-specific).
 - (d) Check that the cooling water pressure or flow is normal (site-specific). If they are not normal, check the cooling water supply valves and strainer.
 - (e) Check that the cooling fans are operating (site-specific).
- (4) If the transformer temperature continues to rise, it may be necessary to unload the transformer.

II. Transformer Oil Flow Failure

- (1) Each transformer is provided with two oil pumps that circulate the oil through water-cooled heat exchangers for cooling purposes. A continuous flow of oil is, therefore, necessary to provide adequate cooling.
- (2) If the alarm does not clear and the plant is unmanned, the Operator should unload the transformer.

- (3) Each pump is provided with a no-flow/low-flow device that energizes the Transformer Oil Flow alarm. This may start a timer that will deenergize the transformer in (site-specific).
- (4) When transformer oil flow failure is indicated by the alarm, Operators should take the following action:
 - (a) Check the transformer temperatures.
 - (b) Check the operation of oil pumps.
 - (c) Check the oil supply valves to make certain they are 100 percent open.
 - (d) Check the oil pump power supply circuits for tripped breakers or overloads.
- (5) Although transformers can be operated for some time without oil circulation, it should be remembered that the winding temperature detectors may not read correctly (local temperature indication) when there is no oil flow. The actual temperatures are likely to be higher than indicated on the recorder, and transformers carrying rated generator load should not be operated with no oil circulation at temperatures above (site-specific).
- (6) The hot spot detector (site-specific) is a better choice for monitoring transformer temperature. The transformer temperature is obtained from embedded resistance temperature detector (RTD) and current/load on the transformer, and this is the one usually fed to the recorder/SCADA.
- (7) If normal oil flow cannot be restored, the associated units should be unloaded, shut down, and the transformers should then be deenergized.

JJ. Sudden Pressure Relay

- (1) The operation of a sudden pressure relay is an indication of a large internal fault in the transformer.
- (2) When the sudden pressure relay operates, it should trip the transformer differential lockout relay, and the Operator should take the following action:
 - (a) Ensure the associated generator and switch yard breakers are open.

- (b) Ensure the lockout tripped and properly operated by verifying appropriate circuit breakers opened, fire water deluge system activated, etc. (site-specific).

CAUTION: Care should be taken not to deenergize the transformer oil pumps on operating transformers.

- (3) Stop the transformer oil pumps (if accessible).
- (4) Check for fire at the transformer and turn on the water spray if necessary.
- (5) Ensure the associated generators are shut down.
- (6) Units should not be restarted until the cause of the relay action has been investigated and corrected.

KK. Transformer Oil and Gas Alarm

- (1) The transformer oil and gas alarm will be energized by any of the following abnormal conditions:
 - (a) Low oil level
 - (b) Low cylinder gas pressure
 - (c) High or low transformer gas pressure
 - (d) Relief valve failure
- (2) When the alarm is energized, the Operator first should try to determine which abnormal condition caused the alarm.
- (3) If the oil level gauge indicates low oil level, the Operator should check for oil leakage at the following:
 - (a) Transformers
 - (b) Heat exchangers
 - (c) Connecting piping
- (4) Low Cylinder Gas Pressure is energized at (site-specific) and indicates that it is time to replace the nitrogen cylinder with a new one. The cylinder normally can be left until maintenance personnel can replace it.

- (5) The nitrogen gas pressure in the transformer is self-regulating in that gas is added from the cylinder when the pressure is too low (site-specific) and is vented to the atmosphere by a pressure relief valve when the pressure gets too high (site-specific).
- (6) If the pressure is low, the Operator should check that the gauge is reading correctly and that the automatic regulating system is functioning to add gas to the transformer.
- (7) If the pressure is high, check that the relief valve is operating. If it is not, slowly open the sampling or vent valve to release enough gas to clear the alarm.

LL. Low Oil Pressure/Level for Transformers with Conservator Tank

- (1) Some transformers are equipped with a constant oil pressure system. The system consists of a conservator tank, a urethane or rubber bladder, a pressure-vacuum bleeder and gauge, and an oil level indicator.
- (2) As oil expands and contracts following loading levels and ambient temperature, the bladder expels air to the atmosphere or allows air into the bladder from the atmosphere. These systems are designed to regulate the reservoir pressure between (site-specific) and will alarm outside those settings.
- (3) Check the pressure gauge for an accurate reading.
 - (a) Check the oil level indicator. If the bladder is damaged or ruptured, a low indication should be present, but the conservator tank will still be functional. Some conservator tanks have a bladder failure relay (site-specific).
 - (b) Check for oil leaks at the main tank, conservator, and piping.
 - (c) Monitor transformer temperatures and loading until such time that the transformer can be removed from service for repair.